

**328**

Ain Lääne and Pertti Heinonen (eds.)

# Sampling

Presentations of three training seminars about Quality Assurance (QA), Biological methods of Water Framework Directive and Waste water sampling techniques

**328**

Ain Lääne and Pertti Heinonen (eds.)

# Sampling

Presentations of three training seminars about Quality Assurance (QA), Biological methods of water Framework Directive and Waste water sampling techniques



Helsinki 2003  
SUOMEN YMPÄRISTÖKESKUS

ISBN 952-11-2053-3  
ISBN 952-11-2054-1 (PDF)  
ISSN 1455-0792

Helsinki 2005

## Content

Preface ( <b>Harry Liiv</b> ).....	4
Introduction ( <b>Ain Lääne and Pertti Heinonen</b> ).....	5
<b>Pertti Heinonen:</b> The trend of quality assurance in the Finnish environmental research and monitoring programmes, the effect of international obligations.....	7
<b>Pertti Heinonen:</b> The detailed structure of the Finnish system "Certification of persons in the environmental sampling".....	9
<b>Ari Mäkelä:</b> Quality aspects concerning water sampling from rivers and lakes in Finland.....	13
<b>Sirpa Herve:</b> Experiences of the co-operation between the laboratories of the water authorities and private laboratories on regional level to improve data production.....	15
<b>Karin Pachel:</b> On receiving water and self monitoring in Estonia and Viru-Peipsi project-area with regard to drafting water resource management programs.....	19
<b>Anneli Joutti:</b> The sampling of soil and solid wastes.....	36
<b>Markku Puupponen:</b> Quality control in hydrological monitoring.....	40
<b>Pertti Heinonen:</b> Introduction to the biological elements of EU Water Framework Directive; phytoplankton as an example in ecological classification.....	42
<b>Ingmar Ott:</b> Phytoplankton as a tool to classify ecological status of lakes. Estonian experiences..	48
<b>Sirpa Herve:</b> Chlorophyll <i>a</i> as an estimate for phytoplankton in ecological classification.....	57
<b>Jarkko Leka:</b> Macrophytes as a tool to classify ecological status of lakes.....	60
<b>Helle Mäemets:</b> Macrophytes - a tool to classify ecological status of lakes, Estonian experience..	65
<b>Sirpa Herve:</b> Mussels in estimation of organic compounds and heavy metals in classification of the chemical status of surface waters.....	70
<b>Sirje Vilbaste:</b> Periphyton as a tool to classify ecological status of inland waters.....	75
<b>Sirpa Herve:</b> Estimation of periphytic growth on artificial substrates and sliming of nets.....	82
<b>Esa Koskenniemi:</b> Zoobenthos monitoring in freshwaters and the challenge of the EU Water Framework Directive.....	85
<b>Henn Timm:</b> Benthic invertebrates as a tool to classify ecological status of inland waters. Estonian experiences.....	89
<b>Bruno Lemiere:</b> A practical guide for sampling methods of wastewater .....	95
.....	3

## Preface

The implementation of the Water Framework Directive is a big challenge for all member states of the European Community. Especial signification of the Directive is for the new member states. The reorganization of water management in Estonia started in early nineties based on the international agreements and taking into account western practice on water protection. The reorganization of the monitoring systems started at the same time with the aim to collect more comprehensive information about status of water bodies for better management as well as to fulfil obligations taken in frame of international conventions.

Since from 2000, the implementation of the Water Framework Directive together with other "water directives" as the urban waste water directive, the drinking water directive and the bathing water directive has influenced significantly on monitoring activities in Estonia. To guarantee high level and comparable monitoring results a lot of seminars and workshops on different aspects of monitoring were organized by the Ministry of the Environment of Estonia.

One of the tasks of the LIFE project "Viru-Peipsi catchment area management plan" financed by European Commission, French Environment Fond and the Ministry of the Environment of Estonia is to continue the work started by the Ministry of the Environment and carry out the training of specialist in the field of monitoring to ensure the sampling capacity for the implementation of the monitoring programme in 2007 according to the Directive.

The sampling seminars organized by the project in close co-operation with Finnish and French specialists are serious inputs to strengthen Estonian monitoring capacity. I hope that the present publication will be taken with big interest by monitoring specialist.

Harry Liiv

Deputy Secretary General on Environmental Management  
Ministry of the Environment  
Estonia

## Introduction

Elaboration of the water management plan following the Water Framework Directive (WFD) by the end of the year 2008 is a big challenge to all the members of the Community. This presumes the revision of legal acts regulating water monitoring, permit systems and implementation of control measures to reduce discharges from different pollution sources. Special attention should be paid to hazardous substances accumulating in ecosystems and creating harm to population.

The implementation of new water policy is closely connected to monitoring of ecological status of water bodies, to waste water discharges and to the results of the implementation of water protection measures. The Water Framework Directive dedicates big attention to the different types of monitoring defining surveillance, operational, investigating and self monitoring.

The implementation of monitoring programmes begins with elaboration of detailed sampling procedures including: parameters to be sampled, handling, transport and storage procedures, sampling frequency and time-schedules as well as quality assurance problems. Monitoring of chemical composition of water bodies and discharges has been widely used than biological monitoring of ecological status of rivers, lakes and costal waters which is one of the basic elements to assess the status of water bodies.

The aim of the LIFE-Environment project “Viru-Peipsi catchment area management plan” is to support the Ministry of the Environment and County Environment Services to start the implementation of the Water Framework Directive. The project includes identification of needs for sampling and monitoring and also organization of sampling campaign and training in water sampling. Following the project plan the training is divided in three parts covering the following topics: quality assurance (QA) in environmental sampling, the biological methods used in the implementation of the Water Framework Directive and the training of waste water sampling techniques.

All three topics are important for specialist responsible for elaboration of water management plans. Different training in the field of accreditation, quality assurance and waste water sampling were organized by the Ministry of the Environment in previous years. Corresponding certification system for sampling personnel is adopted by the Ministry and only specialists having a licence are allowed to take samples.

By the moment biological sampling has been carried out by scientists from universities and specialists from the County Environment Services were not involved to the biological sampling program. Therefore, the topic concerning those biological determinands, which are obliged by WFD, is crucial one for the specialist of the County Environment Services to understand and interpret different biological indicators and to use them for assessment of the status of water bodies. The further need for such kind seminars on biological sampling was expressed by Estonian and Latvian participants on the seminar.

To guarantee the high level of trainings the specialists from the Finnish Environment Institute (SYKE) and from French Geological Survey (BRGM) were involved in addition to local specialists. Concerning biological and waste water sampling training the field work has been organized to acquire complicated biological sampling methods and to fix theoretical knowledge on automatic water samplers.

In addition to the three seminars the training to use the automatic flow measurement devices (Acoustic Doppler Profiler, Sontek River Surveyor) bought by the project were organized by deliverer ELKE Sensor.

In co-operation the Viru-Peipsi CAMP and SYKE were collected the most important presentations of the seminars and published in the proceeding of SYKE. Taking into account that the WFD monitoring programme should start in the beginning of 2007 we hope that the printed seminar materials will help specialist to carry out the programme according to the requirements of the Water Framework Directive.

Ain Lääne

Viru-Peipsi CAMP  
Project Manager

Pertti Heinonen

Finnish Environment Institute SYKE

# The trend of quality assurance in the Finnish environmental research and monitoring programmes; the effect of international obligations

Pertti Heinonen  
Finnish Environment Institute SYKE  
P.O.Box 140  
00251 Helsinki  
Finland  
pertti.heinonen@ymparisto.fi

## Abstract

The target of environmental monitoring is with certain intervals repeated measurements of relevant characteristics with comparable (usually standardized) methods to follow changes and trends in nature and the environment over a (longer) period of time. The most important part of monitoring is the differentiation of the anthropogenic variations and trends from natural cycles and possible long-term trends.

The need for quality assurance in all phases of monitoring is quite high, because the objects of monitoring are difficult ones: e.g. the concentrations of most harmful pollutants are usually very low, and there is always spatial and temporal variation, especially in biological determinands, which in cases of pollution and eutrophication can be significant.

The regular water quality monitoring carried out by water administration started in Finland in 1961, when the Water Act came into force. The very first national monitoring network consisted only of the sampling sites, where water quality of rivers was determined, but step by step our national monitoring increased and at the moment it covers all the main topics in the water environment. From the very early beginning the Quality Assurance (QA) aspects have been taken to the monitoring programmes.

The first target to improve the quality of monitoring activities was the laboratory work. The importance of standardization was understood, and the first standards were developed with the Nordic countries, especially with Sweden.

The very first working group on standardization in the Finnish Environment Institute (SYKE) was established in 1973 (Standardization of chemical characteristics of water). Different groups for chemical, biological, ecotoxicological, microbiological and hydrological measurements were established during 1970s and 1980s. The Co-ordination group of standardization was established in 1995. There are at present some 250 different standards concerning water research.

The Nordic co-operation with INSTA has nowadays in practice stopped, and the new active partners in developing the methodology for environmental research and monitoring are ISO (International Standardization Organisation) and especially CEN (The European Standardization Organisation).

Now we are looking to the future, and more and more to the international obligations of quality assurance. Standards for methods and techniques should be defined for procedures including measurements and sampling, the transport and storage of samples, laboratory analysis, data processing,

data handling (including validation and storage) and data exchange, calculations and statistical work.

International standards should preferably be used in monitoring. If international standards (by ISO or CEN) are not available, or are inadequate for some reason, national standards should be applied or developed. In any case, the documentation of methods should be done as clear and unambiguous as possible. The standards used by riparian countries need not necessary be the same, but they must provide comparable data for e.g. assessment purposes of the status of transboundary water courses and international lakes.

Joint bodies should agree on the standards to be used by riparian countries. Transboundary aspects have been discussed in details in the UNECE Guidance documents for the monitoring according to the Water Convention. All the UNECE guidance books can be found in internet:  
<http://www.unece.org/env/water/publications/pub74.htm>

In addition to the quality control carried out on separate procedures, such as sampling, measurements and analyses, data validation should be an intrinsic part of data handling. Regular controls over newly produced data should include the detection of outliers, missing values and other obvious mistakes. Only when data has been thoroughly checked, and the necessary corrections and additions made, it can be approved and made accessible. To be available for future use, data should be stored in such a manner that it is accessible and complete, with respect to all the conditions and qualifiers covering data collection and analysis.

The EU Water Framework Directive (WFD) assumes that methods used for the monitoring shall follow the international standards, which are available, or which will be developed. The reason is to get an equivalent scientific quality and comparability (Annex V of WFD, 1.3.6).

[WFD (Directive 2000/60/EC of the European Parliament and of the Council of 23 October 2000 establishing a framework for Community action in the field of water policy) can be found in internet: [http://europa.eu.int/comm/environment/water/water-framework/index\\_en.html](http://europa.eu.int/comm/environment/water/water-framework/index_en.html)]

More details about the EU praxis has been presented in the Guidance document n.o 7 "Monitoring under the Water Framework Directive". This Guidance, as well as other guidance documents for implementing EU WFD can be found in internet:  
[http://europa.eu.int/comm/environment/water/water-framework/guidance\\_documents.html](http://europa.eu.int/comm/environment/water/water-framework/guidance_documents.html)

The same idea of QA is added also to the new proposal for EU Bathing Directive. The Guidelines according to this new proposal will be published as standards possible in 2005.

# The detailed structure of the Finnish system "Certification of persons in the environmental sampling"

Pertti Heinonen  
Finnish Environment Institute SYKE  
P.O.Box 140  
00251 Helsinki  
Finland  
pertti.heinonen@ymparisto.fi

## Introduction

The expansion of environmental research and especially of the official monitoring activity to incorporate a greater amount of environmental sectors has increased also the requirement for detailed planning in quality assurance and for the finding of a reliable solution to this development. The character of environmental monitoring has in the same time significantly changed. Also the increase of the importance of the monitoring results in economic sense (e.g. the limit values of some EU directives, classification obligations by EU Water Framework Directive etc.) has increased the demands and obligations for quality assurance and control in all the stages of research and monitoring (Figure 1).

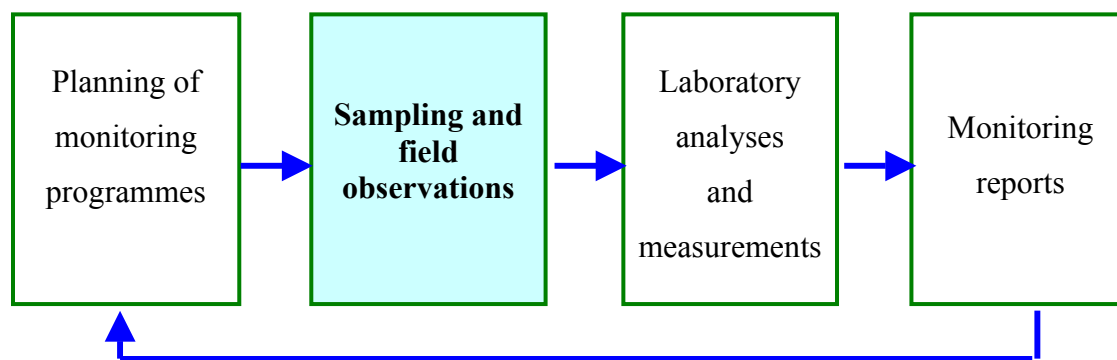

Figure 1. The main stages of environmental research.

Out of all the stages looked at, laboratory operations are relatively the least difficult to solve due to the fact that they have the greater amount of experience collected over a greater amount of time. A very good example of this is how the current accrediting system and well-maintained laboratory inter calibration guarantee the established high level of laboratory results for monitoring purposes. The question at the moment is how do we reliably organise the remaining stages of the research and achieve quality assurance.

Environmental research in Finland including especially the monitoring activity of water resources developed to a larger scale in the 1960s. At that time, the officials of national water administration had, at their disposal, altogether fourteen standard laboratories capable of performing a quite broad set of water analysis.

The law covering water also obligated water polluters to acquire, at their own cost, information on their own waste waters and their recipient waters. For monitoring of waste water loading many big polluters, like pulp and paper mills and large cities started so called "Self monitoring"- practise, which has been of great help in organising monitoring activity.

Development of environmental management brought about many renewal projects. In the late 1990s, after a lengthy process the ministry for the environment obligated the Finnish Environment Institute (SYKE) to establish a quality assurance framework based on the certification of relevant persons for the sampling personnel. Further to this, the procedure necessitated an urgent drafting of a new environmental protection law (in 2000) which also determined quality assurance in measuring and research (108§).

According to this, the implementation of this law requires measuring, testing, observations and research, which must conform to the respective levels of competence, as well as be reliable and according to the appropriate method. The details of these requirements are regulated by the Ministry of the Environment's relevant statutes. Quality assurance in environmental sampling is achieved in an accredited certification of relevant persons.

## **The basis of the certification of persons engaging in environmental sampling**

Quality improvement in environmental research and monitoring is covered by the system for certification of persons engaging in environmental sampling established in the Finnish Environment Institute (SYKE). This offers the possibility to ensure that all applicants conform to the required relative levels of competence in environmental sample taking, as well as environmental measuring and in observing.

Certification actions are in accordance with the standard EN/IEC 17024 (Conformity assessment - General requirements for bodies operating certification of persons). In implementation, the IAF Guidance on the Application of ISO/IEC 17024:2003 has been used. The certification system consists Certification Body and Certification Board.

Special competency fields include at present in Finland following five environmental sectors:

- Water samples and samples from watercourses (it includes sampling from water for household consumption, waste water, surface waters and groundwater)
- Samples from soil and solid wastes (it includes sampling from soil, waste tips and ground water)
- Samples from air and fall-outs (it includes sampling from ambient air and rain water, the certificate does not, however, include the competence for emission measurements, and indoor air measurements)
- Samples from biota (it includes sampling from flora and fauna as well as field operations of samples in different parts of nature, like water courses, forests, fields etc.)
- Measurements and observations in the environment (it includes among others measurements and observations in terrestrial forest surveys, and hydrological assessment of water resources)

Most certificates until now have been accepted for water sector.

## **Requirements for the decision of certification**

The prerequisites of conformity of relevant skill levels is a suitable level of experience acquired in the regular environmental sample taking or environmental measuring or in observing on candidates own main field. A precondition is that he or she has worked for a period of no less than one full year in his or her main field in order for the candidate to confirm his or her conformity to the required level of professional competency.

Prerequisites of conformity to relevant knowledge requirements are that the applicant has successfully completed a approved basic course and a course in a relevant special field, as well as successfully completed all the interviews associated with these courses.

## **Responsibilities and obligations of the certified personnel**

Certificants in their environmental sample taking or environmental measuring must strictly adhere to the required methods of working and recognised practices that, for their part, ensure that such produced information is wholly reliable. Certificants have the responsibility of notifying their employer of deficiencies and faults in environmental sample taking, and which he or she is unable to resolve by his or herself.

Throughout the entire valid duration of the certification of competency certificants are obliged to provide, upon request, from the Certification Body preconditions and explanations. Such explanations cover tasks carried out under the requirements of the certification of competency and attendance in education in his or her relative field. Responding to requests for explanation is one prerequisite for the valid duration of the certificate of competence to continue.

The Certification Body will maintain a register of sample takers which includes relative information on each certificant sample taker. The certificant body will remain in constant contact with certified sample takers and furnish them with relative information on sample taking including development in the relative area, as well as relative literature and educational possibilities.

## **The content of courses relating to knowledge requirements**

Basic courses covering knowledge requirements are to teach and stress the need for correct sample taking, measuring and observation and the significance of this in achieving reliable and competent results. The courses are to address the separate relevant activities and special features of environmental sample taking as well as environmental measuring and in observing. In particular, education is to cover operational quality and quality assurance requirements as well as activities relating to documentation. In addition, the courses are to include starting points of knowledge on operational quality legislature and occupational health and safety requirements.

The content of special courses in knowledge requirements is to teach and stress with the aid of practical examples correct sample taking, measuring and observation. In addition, the requirements concerning correct equipment and tools and their significance in achieving reliable and competent results in each special field's research and monitoring, as well as legislature and other special features. Written performance examinations are organised after the courses under the supervision of the course trainer.

## **Approval of courses relevant to certification**

The Certification Body approves proposals relating to courses concerning knowledge requirements. Such courses are approved only when the relevant level of expertise and the level of independence can be guaranteed. In applying for approval of courses the following must be included:

- a description of the course trainer's experience in professional education,
- the course program,
- a description of the lecturer's education and experience in his or her relative field as well as
- a description of how the written examination and its evaluation will be organised.

## **Validity of the certification of competence**

The certification of competence is valid for a period of five years. Should the certificant have accomplished no less than half the duration of the certification of competency in his or her main field of expertise, or in other regular work in environmental sample taking, as well as attended a certification body approved education to upgrade the level of knowledge, and that he or she has managed sample taking expertly and without cause for complaint then the certification body is authorised to extend the certification of competency for a further five years.

Education to upgrade knowledge must be certified and include at present no less than 30 hours or in other words one day per year. This education is to include teaching in general sample taking as well as in the special field noted in the certification of competence.

## **The present situation of certification in Finland**

The first certificates were accepted in 1999 and altogether some 400 persons have been accepted as certified environmental sampling persons until June 2005. Nearly all persons responsible for environmental monitoring in environmental administration have been certified. The number of accepted persons working in other institutes (including commercial ones) is increasing very quickly. First renewals (after five years) have been already accepted.

One of the main advantages has been, that all the persons participating regularly in the environmental sampling can be identified and followed. The obligatory advanced training will help also the implementation of harmonised methodology. The system has improved also the status of the sampling personnel

This certification system has been accredited by the Finnish Centre for Metrology and Accreditation in May, 2004.

# Quality aspects concerning water sampling from rivers and lakes in Finland

Ari Mäkelä  
Finnish Environment Institute (SYKE)  
P.O.Box 140  
00251 Helsinki  
Finland  
ari.makela@ymparisto.fi

## Introduction

The field work associated with the collection and transport of samples will account for a substantial proportion of the total cost of a monitoring program. As well, the collection and handling of samples are also a frequent source of error, often greater errors than those arising during analyses. Sampling expeditions should, therefore, be planned and carried out such a way the efforts are not wasted. Personnel who will collect water, biota or sediment samples must be fully trained in both sampling techniques and field test procedures. They should also be aware of the objectives of the monitoring program since these will have some influence on the sampling procedures, or on decisions which are to be made in the field with regard to exact sampling locations.

In Finland, we have had a personnel certification system for field technicians since 1999 along the EN/IEC 17024 (Conformity assessment - General requirements for bodies operating certification of persons). In implementation, the IAF Guidance on the Application of ISO/IEC 17024:2003 has been used. The system got its accreditation in May 2004 (Heinonen, article in this publication). The overall aim is "Good Sampling Practice".

The sample collection process should be fully coordinated with the laboratory. Containers for the transportation of samples are best provided by the laboratory. Samples are logged into the laboratory information management system as soon as they have been arrived, and then transferred to a refrigerator. All samples must be clearly and unambiguously identified. Sufficient additional information should follow the samples so that all results can be properly interpreted.

In calculation of loadings of pollutants or nutrients carried by rivers into recipients, it must be noted that flow measurements are equally important as sampling and analysis. As well, there is always a need to check the most homogeneous and turbulent river point for representative samples. Often this is a bridge within white water river reaches.

## Goal

Overall goal is collecting representative samples. The key questions to be highlighted are;

- How do we know that we have collected a representative sample?
- How do we know that we have avoided any form of contamination?
- After transportation and storage of the sample – how do we know that the sample is still representative and valid?
- At the final end, how do we assess and manage the total error caused by components like sampling, transportation, storage and analysis performance?

Quality control activities in sampling have the same objectives as in analysis, to identify, quantify and control sources of uncertainty in sampling and to implement corrective actions when necessary.

## Quality Assurance and Quality Control

Present day's surface water sampling Quality Assurance and Quality Control (QA/QC) framework in Finland is the following;

1. Addressing QA/QC factors in the present day's Environment Protection Code (Environmental Protection Law)
2. Specifically prepared guidelines and guidance documents related to surface water sampling. In all, four overall updates issued during the past 35 years.
3. Certification of field technicians, taking care of their further training and informing on yearly basis fully about monitoring programs they will be involved with.
4. General Technical issues --- continuous improving of field working performance;
  - Sample transport boxes, cooling capacity performance, the target is to achieve +4 °C
  - Sample containers: materials and washing procedures
  - Avoiding temperature increase more than +5 °C during transportation
  - Procedures for calibration of equipment for on-site testing: pH, oxygen temperature, conductivity
  - Sample preservation without causing additional contaminations
  - Initiating certain analyses by fixing the sample
  - Continuous updating and improving Guidelines for collection of water samples
5. Issues related to objectives of monitoring
  - Monitoring plan for a monitoring programme
    - ✓ Criteria for a representative sampling point, for a sampling line or for area
    - ✓ Criteria for appropriate sampling techniques
    - ✓ Criteria for timing of sampling,
    - ✓ Criteria of the types of samples: grab, time-integrated or volume- integrated samples
    - ✓ Quality control routines with regard to sampling; like duplicate samples, field blanks, spiked samples and their control charts for checking up how the routines move ahead along the course of the monitoring program.

## Auditing

Program managers and laboratory personnel should accompany field personnel on field expeditions from time to time. This provides opportunities for field supervision as part of in-service (on-the-job) training and for everyone working on the program to appreciate the problems and needs of field work.

## References

- Bartram J., Mäkelä A. and Mälkki E. 1996. Field work and sampling. 23 p. In: Bartram and Balance. 1996. Water Quality Monitoring. A practical guide to the design and implementation of freshwater quality studies and monitoring programmes. UNEP, WHO. 383 p. ISBN 0-419-22320-7.
- Nyeland B., Mäkelä A., Palsson E., Kvaeven, B., Myklebust, I., Thörnelöf E., Notter M. and Ekedahl G. 1997. Quality Assurance in Environmental Monitoring. A Guidance document. Nordic council of Ministers. TemaNord 1997:591. 86p. ISBN 92-893-0105-8.

# Experiences of the co-operation between the laboratories of the water authorities and private laboratories on regional level to improve data production

Sirpa Herve  
Central Finland Regional Environment Centre  
P.O.Box 110  
40101 Jyväskylä  
Finland  
sirpa.herve@ymparisto.fi

## Introduction

One key principle, which is widely used in all western countries in the context of environmental monitoring, is the "Polluter-Pays-Principle", originally presented by OECD already in 1972. It means among other things that the polluters are responsible for all the costs of the environmental monitoring activity. In Finland it usually means, that e.g. big industrial mills pay to some consultant bureau or private research laboratory to carry out the monitoring programme of the receiving water body, but they take and analyze the samples and also report themselves the amount and quality of the waste water discharges. This "self monitoring" is focused especially in the measurements of the waste water loading.

## The basis for self monitoring in waste water monitoring

The monitoring results cannot be accepted by environmental authority without some kind of quality control system. In most cases this control is implemented in Finland by the regional environmental administration, the regional environment centres (RECs). The normal procedure concerning waste water monitoring is as follows:

- Environmental Permit Authorities decide on the environmental permits for activities having major environmental impacts, taking place under the old Water Act (since 1961) and the new Environmental Protection Act, which came into force in March of 2000, when the Pollution Control Legislation in Finland was revised.
- According to these permits all the waste water discharges should be monitored, and the results should be sent to the regional environment centres (RECs).
- Both quantity and quality of waste waters must be monitored to calculate the total loading to the receiving water bodies.
- As supervisory authorities the RECs are responsible for checking and accepting the monitoring programmes.
- Most common variables in monitoring programmes are BOD<sub>7</sub>, suspended solids, total phosphorus and total nitrogen.
- The EU legislation (e.g. Urban Waste Water Directive and IPPC Directive - Integrated Pollution Prevention and Control) must be taken into account in the programmes.

## The control system of self monitoring

The control system of self monitoring used in Finland e.g. in controlling the monitoring activity of a pulp mill is as follows:

As supervisory authorities the RECs are responsible for checking and accepting the monitoring programmes, which the polluters have prepared themselves.

- The authorities are also obliged to control the implementation of the programmes, and the quality of results.
- RECs have established a control system, which is based on the comparison of the results of simultaneous sampling and analyzing, it means two simultaneous samples, one for the REC and one for the polluter's laboratory.
- These samplings have been carried out without any beforehand made programming and with unexpected intervals.

## The content of the control system

The control system is divided into several parts, which all shall be checked. The normal content of the control system is as follows:

- The procedure of the simultaneous sampling shall be presented in details.
- The observations "on the field" must be clearly described and documented.
- The methods used in the sampling must be documented.
- The observations in the laboratory must be made during the visits.
- The methods used in the laboratory must be checked.
- Sending of the intercalibration results must be clarified.
- The assessment of the control results must be discussed after the results of both laboratories are ready.
- Proposals for actions should be done, if needed.
- The schedule for re-control should be agreed, if some significant differences have been found between the results.

## Control of sampling

The control of waste water monitoring is focused to all possible elements of the programme. It starts with the checking of the sampling equipments and the procedure of the whole sampling. Special attention is paid to observations on the field and the simultaneous sampling with the authority. Before taking the samples, the functioning and the cleanliness of the sampling equipment, the will be checked. Also the waste water discharge must be measured. All the observations must be documented carefully, and accepted by both sampling persons.

In the simultaneous sampling the samples for both parties will be taken by the principle of equal division. The collected sample should first be blended using the mixer of the sampling equipment or by effective manual mixer. The temperature of the sample should be measured to estimate the possible changing of the sample during one day. The samples should be transported to the laboratories as soon as possible taking into account all the guidelines for accurate transport of samples.

The control of sampling can be divided into following issues:

- In the monitoring programme there is always a demand, that the composite sample of the preceding day must be taken at some certain exact moment, e.g. at 06.00 am, no minutes before.
- Beforehand a special agreement has been made between REC and the treatment plant concerned, that the sampling personnel of REC has the permit to come to the plant at any time.
- In the case of control the sampling personnel of REC comes just before 06.00 and without any announcing beforehand.
- Before taking the samples, the sampling equipment will be checked: the volume of the sample, the functioning of the equipment, the cleanliness of especially the tubes (transparent for easier

checking!) as well as the room, where the equipment is placed. The room temperature must be measured.

- The waste water discharge (m<sup>3</sup>/day) must be measured.
- All the observations must be documented carefully, and accepted by both sampling persons.
- The samples for both parties will be taken by the principle of equal division.
- The collected sample should first be blended using the mixer of the sampling equipment or by effective manual mixer.
- Sub samples will be taken by turns to both of the sampler containers of the parties through the tap of the equipment or manually with a small clean bucket.
- If the content of suspended solids is high, the sample should be blended also during the sub sampling procedure before analyzing.
- The temperature of the sample should be measured to estimate the possible changing of the sample during one day.
- The samples should be transported to the laboratories as soon as possible taking into account all the guidelines for accurate transport of samples.

## The laboratory control

The control system contains always the possibility to make visits in the laboratory of the mill concerned to control the methodology, practical work, etc. Accepted standards (CEN, ISO) or methods, which have been tested and accepted together with the authority should be used in all monitoring programmes. The QA-system of the laboratory must be arranged (accreditation, certification). There must be possibilities to check e.g. control cards and the validity of the measurements, as well as instructions and manuals for different equipments and methods etc. The personnel of the laboratory must be competent.

The practical phases of the analyses should be checked. The following procedure can be used in the controlling phase:

- The analyzing of samples starts by dividing the sample to suitable sub samples for different variables.
- It is important to take care of the representativeness of all the sub samples.
- The blending during the sub sampling may be necessary especially in cases where the sample contains a lot of suspended material.
- Checking of the solutions, the condition of equipments, the cleanliness of the laboratory and especially of the laboratory glass wares, instructions and manuals for different equipments and methods etc.
- The compliance with the guidance documents and all the special guidelines of different variables.
- Usually several dilutions must be used (e.g. BOD analyses) to get reliable results. The use of dilutions should be checked.
- The calculations of the mean values are important.
- A part of the primary sample should be retained for possible renewal or checking of the analyses.

An example of the checking is presented in Table 1. In that case the mill has been checked three times (I, II and III). The results of the authority and polluter's laboratory can be compared easily because they have been presented next to each others.

Table 1. Control results of a Finnish pulp mill.

Variable	I	I	II	II	III	III
	Authority	Industry	Authority	Industry	Authority	Industry
Suspended solids (GF/A), mg/L	29	30	62	52	88	59
Conductivity, mS/m (25 °C)	63.5	62.0	49.8	48.0	57.5	56.0
pH	7,40	7,40	8.0	8.0	7,60	7,70
BOD <sub>7</sub> , mg/L	91	85	82	77	80	88
Total nitrogen, µg/L	3800	4080	9 500	10 076	4 700	4 060
Total phosphorus, µg/L	67	81	63	64	120	145
COD <sub>Cr</sub> , mg/L	200	200	210	220	240	240

## Interpretation of control results

The laboratory concerned sends first the results to the authority, and after that the authority sends its own results to the laboratory under control for comparisons. If there are major differences between the results of the authority and the laboratory concerned, the authority asks for chasing up the possible reasons. If the differences are of significant amplitude, the reasons will be discussed together in special expert meetings. If new samples must be taken, the occurrence of error must be estimated: is it systematic or coincidental? If there still is differences in results, some third laboratory can be taken to the trial laboratory can be taken to the trial testing, e.g. some laboratory of the university.

The reason(s) for false results of the certain method must be investigated very carefully starting from the manual and other instructions. Possible reasons can be found from very different details, as the age and the cleanliness of measuring equipments, the cleanliness of glass ware, the age of different dilutions used in analyses. It is real detective work to find the reason(s). Sometimes it is very useful to offer a person from the (self monitoring) laboratory for a shorter visit to train the methods in the laboratory of the authority. If the laboratory continuously fails in analysing certain variables and does not follow the instructions of the authority, their results can not be accepted for monitoring purposes. It means in the worst situation the change of the laboratory.

Control samples must be taken frequently enough, at least 1-2 times a year. If there are problems, they should be solved immediately with new control samples. New samples should be taken as long as the problem has been solved and disappeared, and the situation has been normal for a couple of consecutive control samplings.

## Summary

The control system is essential to make the self monitoring possible. It takes time to establish a reliable control system, but it is advantageous. The maintenance of the system is not so laborious, because, if all goes well, the relations between authority and the laboratory of the self monitoring will be more co-operation than control.

OECD 1972 can be found in internet: [sedac.ciesin.org/entri/texts/oecd/OECD-4.01.html](http://sedac.ciesin.org/entri/texts/oecd/OECD-4.01.html)

# On receiving water and self monitoring in Estonia and Viru-Peipsi project-area with regard to drafting water resource management programs

Karin Pachel  
Estonian Environment Information Centre  
Mustamäe tee 33  
Tallinn  
Estonia  
Karin.Pachel@ic.envir.ee

## Introduction

This paper discusses national and international legislation regulating water monitoring both in the European Union and Estonia. More attention has been given to international obligations and topics related to self-monitoring of receiving waters and companies, which have received less attention in reports and reviews drawn up within the framework of other projects.

The basis for the paper is the principle of integrated water management in river basins, stated in European Union Water Framework Directive, attaching an important role to monitoring. Monitoring is expected to give continuously competent overview of water quality by basin where planning, management and monitoring are applied as a part of single, constantly changing cycle:

Monitoring ⇒ assessment of status ⇒ planning of measures ⇒ implementation of measures ⇒ monitoring ⇒ adaptation of planned measures and monitoring plan, if necessary ⇒ implementation of measures ⇒ monitoring ⇒

## General information on monitoring

The purpose of environmental monitoring is continuous surveillance of environmental development, explaining the changes and their trends, supplying the reference data for planning measures for environment protection, their implementation and evaluation of their efficiency. The task of environmental monitoring is to observe the movement of various contaminants and their impact on environment, while providing the basis for assessing environmental quality.

Management of water bodies is based on information concerning the quality of water of a given basin. Information about quality of water allows to focus the development of water resource management while providing assistance for passing the decisions concerning water use and environment protection through the issue of water use permits, choosing the location for buildings and establishing building terms and conditions, setting limits to production and pollution, choosing of production and waste water treatment technologies, setting priorities for expedient funding of buildings erected for environment protection purposes and drafting of legislation.

Monitoring plan should be long-term and persistent while developing smoothly to match the changing factors and involve new arising environmental hazards. The scope of monitoring depends on specific environment, intentions, economy, interest, competence and interested parties. Environmental monitoring data is required for planning purposes. Monitoring also sets obligations for authorities.

## Objectives, tasks and types of monitoring

Authorities responsible for organising monitoring are aiming at:

- observing changing of environmental conditions in time;
- discovering new environmental risks;
- obtain a picture of environmental status of whole country, county or local administrative unit;
- evaluation of results at fixed intervals to provide for the adoption of protective measures for controlling hazards detected;
- assurance of research and surveillance of different factors in environment;
- assurance of the availability of basic materials required for planning purposes;
- provision of access to comparative data (for example, results of work conducted by environmental inspectorate);
- provision for compatibility of national and international reports;
- assurance of quality control over data and their recording by method providing for comparison and evaluation of data;
- organisation of publication and dissemination of monitoring data.

Monitoring can be conducted:

- at national level by establishing domestic and international requirements and benchmarks, national databases and national protective measures;
- at regional (for example, basins or counties) level by adopting appropriate objectives and action plans;
- at local government level by implementing local comprehensive plans and action plans;
- in single catchment area;
- at company level within the area its activities affect;
- for monitoring receiving waters.

In Estonia, the Environmental Monitoring Act makes a distinction by national environmental monitoring, environmental monitoring carried out by local government and environmental monitoring carried out by undertaking.

The law does not provide for regional environmental monitoring at county level.

## European Union demands and requirements

Water pollution is a big problem all over European Union (EU). EU's water protection directives can be grouped under the following categories:

- 1) Dealing with the quality of surface water earmarked for specific water use. In the 1970ies, as the quality requirements were established for drinking water, water intended for washing, water used by fish farms, etc. this used to be literally the only category dealt with.
  - directive 75/440/EEC concerning the quality required of surface water intended for the abstraction of drinking water (SURFACE WATER DIRECTIVE);
  - directive 76/160/EEC concerning the quality of bathing water (BATHING WATER DIRECTIVE);
  - decision 77/795/EEC establishing a common procedure for the exchange of information on the quality of surface fresh water in the Community;
  - directive 78/659/EEC on the quality of fresh waters needing protection or improvement in order to support fish life (FISHING WATERS DIRECTIVE);

- directive 79/869/EEC concerning the methods of measurement and frequencies of sampling and analysis of surface water intended for the abstraction of drinking water (DRINKING WATER AND DRINKING WATER ANALYSING DIRECTIVE).

2) Water use and waste water discharge of different industries. This group includes directives dealing, for example, with production emitting titanium oxide and agriculture emitting nitrates but also waste water produced by chemical pulp and paper factories and urban settlements.

- directive 91/676/EEC concerning the protection of waters against pollution caused by nitrates from agricultural sources (NITRATE DIRECTIVE);
- directives 91/271/EEC, 93/481/EEC concerning urban waste-water treatment (URBAN WASTE WATER DIRECTIVE)
- directive 86/278/EEC on the protection of the environment, and in particular of the soil, when sewage sludge is used in agriculture (SEWAGE SLUDGE DIRECTIVE)
- directive 96/61/EC concerning integrated pollution prevention and control (IPPC DIRECTIVE)

3) Discharging certain dangerous substances into the aquatic environment. These directives deal with dangerous substances divided between I or the 'black' list (substances that must not be discharged into aquatic environment) and II or the 'grey' list (substances that may be discharged into aquatic environment if certain conditions are met).

- directive 76/464/EEC on pollution caused by certain dangerous substances discharged into the aquatic environment (DANGEROUS SUBSTANCES DIRECTIVE) and related daughter directives 82/176/EEC, 83/513/EEC, 84/491/EEC, 86/280/EEC, 88/347/EEC, 90/415/EEC.

4) Development of general aquatic environment protection policy

- directive 2000/60/EC establishing a framework for Community action in the field of water policy (WATER FRAMEWORK DIRECTIVE);
- decision 92/446/EEC concerning questionnaires relating to Directives in the water sector;
- directive 2001/42/EC on the assessment of the effects of certain plans and programmes on the environment (STRATEGIC ENVIRONMENTAL ASSESSMENT DIRECTIVE)
- Council Regulation (EEC) No 1210/90 on the establishment of the European Environment Agency and the European Environment Information and Observation Network;
- directive 90/313/EEC on the freedom of access to information on the environment.

The European Union and its Member States are participants to numerous international conventions that establish important obligations for protecting seawaters from pollution. The most important for Estonia are the Helsinki Convention on the Protection of the Marine Environment of the Baltic Sea Area (HELCOM), signed on April 9, 1992 in Helsinki and ratified with the Commission Decision 98/249/EC. Water Framework Directive is expected to contribute to fulfilment of the aforementioned obligations by the Community and the Member States.

## Obligations arising of conventions

The Convention on the Protection of the Marine Environment of the Baltic Sea Area was signed in 1974 in Helsinki. Estonia joined the Convention in 1992. The Convention's main goal is to protect the marine environment of the Baltic Sea from all sources of pollution, and to restore and safeguard its ecological balance. This goal is being implemented by the Protection of the Marine Environment of the Baltic Sea Commission, HELCOM or the Helsinki Commission, joined by all the countries around the Baltic Sea.

Helcom requires continuous information regarding the pollution load of the Baltic Sea. Previously, four reports have been prepared – on years 1985, 1990, 1995 and 2000 (PLC-4). The guidelines have been provided in HELCOM Guidelines 20/1999.

Within the framework of PLC-4, the total pollution load of the catchment area was determined, both with regard to diffuse and point sources of pollution. Guidelines are available, describing the methods for determining pollution in case of rivers not being under monitored or under partial monitoring, but also for considering the pollution provided by coastal catchment areas and natural pollution load. Loads contributed by municipal and industrial waste water overflows and discharges need to be determined separately. Pollution loads provided by agriculture and fish farming needs to be calculated.

Run-off needs to be determined, the purpose being to assess the pollution load discharged to the Baltic Sea by rivers. Rivers with run-off  $>5\text{m}^3/\text{s}$  must be under continuous monitoring. Guidelines WMO Guide to Hydrological Practices (WMO-No. 168, 1975) and ISO 5667-6 and ISO 5667-9 standards serve as the basis for determining run-off.

In Estonia, there are 15 river hydrochemistry stations belonging to Helcom's monitoring network whereas six of them – Narva river in Narva, rivers Pühajõe, Purtse, Kunda, Selja at the mouth and river Loobu at Vihasoo belong to Viru-Peipsi project-area.

According to the Convention on Protection & Use of Transboundary Watercourses and Lakes (Helsinki, March 1992), the Parties shall, in particular, take all appropriate measures to prevent, control and reduce any transboundary impact. Above all, the parties must take all the appropriate measures to avoid, control and reduce pollution of waters causing or likely to cause transboundary effect; to ensure that transboundary waters are used with the aim of ecologically sound and rational water management, conservation of water resources and environmental protection; to ensure that transboundary waters are used in a reasonable and equitable way, taking into particular account their transboundary character, in the case of activities which

Article 4. *Monitoring* – states the Parties shall establish programmes for monitoring the conditions of transboundary waters.

Article 11. *Joint monitoring and assessment*. In the framework of general cooperation or specific arrangements, the Riparian Parties shall establish and implement joint programmes for monitoring the conditions of transboundary waters, including floods and ice drifts, as well as transboundary impact. The Riparian Parties shall agree upon pollution parameters and pollutants whose discharges and concentration in transboundary waters shall be regularly monitored.

Article 13. *Exchange of information between riparian parties*. The Riparian Parties shall, within the framework of relevant agreements or other arrangements exchange reasonably available data, inter alia, on environmental conditions of transboundary waters; experience gained in the application and operation of best available technology and results of research and development; emission and monitoring data; measures taken and planned to be taken to prevent, control and reduce transboundary impact; permits or regulations for waste-water discharges issued by the competent authority or appropriate body.

## Obligations arising of bilateral international agreements related to waters

The goal of agreement between the Government of the Republic of Finland and the Government of the Republic of Estonia on Cooperation on Water Protection (Tallinn, February 12, 1999) is promoting water protection and related environment protection in Estonia and Finland for assuring sustainable development. The parties shall attempt to reduce and prevent pollution load of bodies of water, above all, the Gulf of Finland, by applying the best technologies and best environmental practises.

With regard to settlements, both states shall take necessary measures for treating waste-water from settlements to achieve the treatment level of 90% regarding elimination of organic substance and phosphor by the end of 2005. The average content of organic substance in waste water discharged to bodies of water must be  $\leq 15$  mg/l (measured using BOD<sub>7</sub>) while the average content of total phosphorus should be  $\leq 1,0$  mg/l, including emergency discharges and overflows. By the end of 2005, waste-water discharged to bodies of water sensitive to nitrogen from settlements with population over 10,000 must be treated of nitrogen with at least 50% efficiency.

The parties shall take measures to supervise pollution load contributed by waste-water treatment plants, the treatment level and pollution load applied to receiving bodies of water.

Where it regards industries and energy production, the parties shall take measures to provide for the monitoring of all the factors affecting environment so as to reduce the discharge of harmful substances, above all, heavy metals, toxic and non-readily degradable organic matter and nutrients from all industrial undertakings by modernising production and waste water treatment technologies with the purpose of cutting the pollution load contributed to bodies of water by the aforementioned substances by 50% by year 2005, when compared to the respective indicators of 1995.

In Estonia, as a rule, municipal and industrial waste waters are all together treated in waste water treatment plants of a given settlement. The number of industries with separate treatment facilities is limited. There are 46 water treatment plants of settlements in Estonia, having the pollution load that exceeds 2,000 population equivalents, 18 of which are located in Viru-Peipsi project-area. 12 of them have a discharge directly to coastal sea; 4 of which – Kohtla-Järve, Sillamäe, Aseri and Kunda municipal waste-water discharges fall under Viru-Peipsi project-area. All the discharges have been issued special water use permit accompanied with the requirement for pipe-end and receiving body of water monitoring and submission of annual water use report. According to legislation in force in Estonia, the data is submitted to county environmental services, forwarding the required information to state water cadastre. In Estonia, the total number of units submitting annual water use reports totals to 1,200.

Agreement between the Government of the Republic of Estonia and the Government of the Republic of Finland on Cooperation in the field of Combating Oil Spills (Helsinki, December 8 1993) requires the parties to take care of conducting supervision within their area of responsibility for the purpose of detecting pollution damage and, if possible, implementation of measures for the elimination of pollution damages and provision of mutual assistance. More specifically, the agreement states competent authorities of the parties and their obligations regarding the issues of notifying of pollution damages, provision of assistance, supervision of activities related to elimination of pollution damages and organisation of specific assistance. The agreement also deals with the issues for compensating for expenses and damages.

Agreement between the Government of the Republic of Estonia and the Government of the Russian Federation on Cooperation in the field of Protection and Sustainable Use of Transboundary Watercourses (Moscow, August 20, 1997) states that the purpose of the agreement is the organisation of

cooperation on transboundary watercourses belonging to basin of Narva River and the protection and sustainable use of their ecological systems. Besides the appointment of competent authorities and joint committee and defining their working principles the agreement also specifies the obligations of the parties with regard to monitoring, scientific research, normatives, standards and consultations. The agreement also gives the principles of cooperation for liquidation of emergency situations and for communicating with local authorities and population in general.

*Article 5. Estonian-Russian joint committee for protection and sustainable use of transboundary watercourses.* According to this article the parties must establish the Estonian-Russian joint committee for protection and sustainable use of transboundary watercourse for the coordination of the efforts of the parties and implementation of the agreement, the main tasks of the aforementioned committee being coordination of the activities of the parties; discussion of the results/outcomes of work conducted; harmonisation and endorsement of scientific research, monitoring and other plans, projects and programmes referring to transboundary watercourses; organisation of development of normative water quality indicators and methods of analysis; elaboration of recommendations for the improvement of national legal acts of the parties, concerning transboundary watercourses and organisation of current and operative information exchange with regard to the condition of transboundary watercourses.

*Article 7. Monitoring.* This article requires the parties to conduct monitoring according to the programmes endorsed by the committee and using their own funds within their respective territories to obtain current information concerning the condition of transboundary watercourses. Monitoring data shall be accessible to both parties. The parties shall exchange monitoring data, obtained within the framework of harmonised programmes.

The joint committee has endorsed a monitoring programme concerning rivers, referring to the monitoring conducted within the framework of national monitoring programmes of both parties. In Estonia, 8 monitoring stations on 7 rivers, included in national programme for monitoring of hydro-chemical processes in rivers, are also part of Estonian-Russian monitoring programme of transboundary watercourses: river Piusa at the bridge on Väraska-Saatse highway, river Võhandu beyond Räpina, river Emajõgi at Kavastu, river Rannapungerja at bridge on Iisaku-Avinurme highway, river Mustajõgi at Mustajõe, river Narva at Vasknarva and river Narva at Narva. As for the hydrometrics of rivers, the programme involves river Võhandu at Räpina, river Tagajõgi at Tudulinna, river Rannapungerja at Roostoja, river Emajõgi at Tartu and river Narva at Vasknarva – in total, 5 stations of hydrometrics.

Agreement between the Government of the Republic of Estonia and the Government of the Republic of Latvia on Environmental Impact Assessment in a Transboundary Context states that the goal of the agreement is to take appropriate measures, whether jointly or separately, for avoiding considerable unfavourable transboundary impact arising of intended activities. Planned activities, observed as specific objectives of the cooperation, are listed in the annex to the aforementioned agreement.

Agreement between the Ministry of Environment of the Republic of Estonia and the Ministry of Environment of the Republic of Latvia for Protection and Sustainable Use of Transboundary Watercourses (Palanga, October 24, 2003) takes into consideration the environment protection agreement concluded between the Republic of Latvia, the Republic of Estonia and the Republic of Lithuania and signed in Tallinn on July 21, 1995. The parties, when applying the requirements to transboundary watercourses, stated in Water Framework Directive 2000/60/EC, being aware of the fact that close cooperation in the sphere of sustainable use and management of international receiving bodies of water contributes to the strengthening of good neighbourly relations, have concluded an agreement about the following:

Article 1 states that the purpose of the agreement is to assure the cooperation between the parties to the agreement for the protection and sustainable use of receiving bodies of water of transboundary watercourses and for the management of joint international basin.

Article 2 determines the scope of cooperation: the parties shall cooperate to establish and manage international Koiva/Gauja basin, preparation of water resource management plan and assure the implementation of Koiva/Gauja water resource management plan within their respective territory.

A working group for the establishment and management of international Koiva/Gauja basin (hereinafter the working group) is formed for the implementation of the agreement. Both parties shall inform each other of the appointment of associated chairman within one month as of the enforcement of the agreement. The aforementioned associated chairmen shall act as the contact persons of the parties for the implementation of the agreement until the first meeting of the working group.

As specified in Article 4, the parties are to harmonise their international basin monitoring programmes and coordinate the sampling methods applied by their respective laboratories while exchanging information and data required for the cooperation related to the establishment and management of international Koiva/Gauja basin. The working group shall determine the procedure for the exchange of aforementioned information and data.

Agreement between the European Community and the Republic of Estonia concerning the Republic of Estonia's participation in the European Environment Agency and the European environment information and observation network. The purpose of monitoring and information network, developed by European Environment Agency, is to provide the European Union, legislation, organisation of aquatic environment at national level and the public in general with data required for that purpose (as stated in the European Union Water Framework Directive).

European Environment Agency's (EEA) Monitoring and Information Network for Inland Water Resources should provide information on:

- the status of river, lakes and ground water by both the properties of water and water resources (current status and trend);
- relations between the load applied to aquatic environment and conditions (relations between the reason and consequence).

Monitoring from national monitoring programmes are chosen to participate in the European Environment Agency's Monitoring and Information Network for Inland Water Resources. The minimum number of EEA-stations for Estonia should be 45 river stations and 26 lake stations (EEA homepage: [reports.eea.eu.int/technical\\_report\\_2003\\_98/en](http://reports.eea.eu.int/technical_report_2003_98/en)). At present, 53 river hydro-chemistry monitoring stations under Estonian national programme also operate under EEA-network. 34 of these stations belong to Viru-Peipsi project-area.

## **Estonian legislation for planning and implementation of environmental monitoring water policy**

There are a number of legal acts in Estonia, dealing with environmental legislation, water monitoring and assessment of use of water.

Laws

- Environmental Register Act,
- Water Act,

- Environmental Monitoring Act;
- Integrated Pollution Prevention and Control Act

#### Regulations of the Government of the Republic

- Statutes of the National Water Cadastre,
- Procedure for Discharging Waste Water to Water Bodies or into Soil
- Water Protection Requirements Applicable to Sewage Facilities

#### Regulations of the Minister of Environment

- Water classes of surface bodies of water, values of quality indicators matching water classes and the procedure for determining water classes
- Specified Procedure for Data Exchange Defined Under International Agreement
- Procedure for the Conduct of National Environmental Monitoring Sub-programmes
- Procedure for Issue, Amendment and Revocation of Special Water Use Permits and Temporary Special Water Use Permits, List of Documents to Accompany the Application for Permit and Formats of Permits
- Lists of Substances Dangerous for Aquatic Environment 1 and 2
- List of Water Bodies Protected as Habitats of Salmon and Cyprinidae and Water Quality and Monitoring Requirements Applying to Such Water Bodies and National Environmental Monitoring Stations Conducting Surveillance Over Salmon and Cyprinidae
- List of Spawning Grounds and Habitats of Salmon, River Trout, Sea Trout and Grayling
- Establishment of Water Protection Requirements for Building and Utilisation of Amelioration Systems and Facilities
- Approval of List of Water Bodies Used as Waste Water Recipients of the Parts thereof Based on Their Sensitivity to Pollution
- Requirements Specifying the Substance of Integrated Environmental Permit and Formats for Integrated Environmental Permits

#### Regulations of the Ministry of Social Affairs

- Drinking Water Quality and Control Requirements
- Quality and Control Requirements Applicable to Surface or Ground Water Used for Drinking
- Health Protection Requirements Applicable to Bathing Areas and Bathing Water.

## **Monitoring purposes and provision thereof**

The quality of water-related policies, activities and planned measures, also development of efficient aquatic environment standards is directly dependent on quality and scope of environmental monitoring.

Water monitoring may conditionally divided into five categories, using the European Union directives and Estonian and international legal acts:

- Surveillance monitoring, monitoring for screening purposes that provides a general overview of the condition of water bodies located within the boundaries of a country, involving the monitoring over pollution leaving the country and transboundary water-courses (continuously working (main) support network funded by the state and changing in time as little as possible and a network of repetitive monitoring, applied at regular intervals, as an addition to the support network);

Estonian national (main) support network involves 61 hydro-chemistry monitoring stations on rivers, 29 of them are flux stations. There are 34 monitoring stations in Viru-Peipsi project-area, 12 being flux stations at estuaries. Monitoring repeated at fixed intervals is not conducted as an addition to support network monitoring.

As for river biology, the national monitoring programme includes every year 55 stations on 5 rivers (including also the most important tributaries), being subject to monitoring at every 5 years. Monitoring of macro invertebrates has been conducted in rivers at the catchment of the Gulf of Finland since 1997.

- Operational monitoring, operative monitoring, allowing to determine the scope and intensity of human impact regarding to both the pollution from point and diffuse sources in catchments of water bodies while meeting the requirements for control and reporting stated in European Union directives and Estonian legislation (network for conducting monitoring over receiving bodies of water, reflecting the human impact, financed by the state, local government and/or undertakings and changing at certain intervals).

Where it regards to pollution from diffuse sources, an area about 3 000 km<sup>2</sup>, has been earmarked in Estonia in Pandivere and Adavere-Põltsamaa region, as specified in Water Framework Directive and Water Act, within an area related to agricultural production, defined as Pandivere and Adavere-Põltsamaa nitrate-sensitive regions. Water quality is under monitoring in 4 rivers: Võisiku main ditch at Võisiku section, river Põltsamaa at Rutikvere section, Alastvere main ditch at section on Põltsamaa-Jõgeva highway and river Jänijõgi at Jäneda. Võisiku, Põltsamaa and Alastvere characterise the condition of surface water of Adavere-Esku region in Viru-Peipsi project-area.

Where it regards the pollution from point sources, as specified in Urban Waste Water Treatment Directive and Government or the Republic regulation No 269 of July 31, 2001 – Procedure for Discharging Waste water to Water Bodies or into Soil (amended with regulation no 327 of 19.12.2003) – undertaking's obligation to conduct environmental self-monitoring should be applied at least in settlements where the pollution load exceeds 2,000 population equivalents. There are 46 settlements matching this criterion in Estonia, 18 of them in Viru-Peipsi project-area.

- Investigative monitoring, research monitoring (incl. scientific research, being related to defined and in long-term sense – a short period of time – can be divided into two groups in principal:
  - ✓ supporting the definition of monitoring network for previous monitoring network and proving the grounds for adjusting it upon the appearance of new (additional) indicators or disappearance of earlier ones;
  - ✓ elaboration of a monitoring network for water bodies earlier not covered by network to explain the reasons for changes having taken place in water bodies; establishment of a monitoring network that characterises the catchment well enough during the development of water management plan for basin or preparation of another project; for detection of contradictions between the present situation of a water body, natural condition and plans people have for it, serving as the basis for devising an economically and socially grounded water protection measures.

According to Article 4 of WFD, the Member States shall protect, enhance and restore all bodies of surface water with the aim of achieving good surface water status at the latest by year 2015. If monitoring for screening purposes reveals that this objective can't be probably reached, research monitoring shall be conducted. There may be about ten rivers or sections of rivers, matching this description, in Viru-Peipsi project-area.

- Background monitoring of nature unspoilt by human activities or background water monitoring, aimed at assessing the condition of a water body that has not been affected by people while providing the assessment grounds for comparing deviations from natural situation and the scope of human impact (national reper network);

The following nine rivers under national monitoring are considered to be natural by their status: Vihterpalu, Puditsoo, Tagajõgi, Reiu and Saarjõgi and upper courses of rivers Õhne and Ahja and river Võhandu at the outflow from Lake Vagula. Natural landscapes (forests, meadows, etc.) are prevalent in the basins of these rivers and the importance of fields is relatively low. There are four of such rivers in Viru-Peipsi project-area 4 – Tagajõgi, upper courses of rivers Õhne and Ahja and river Võhandu at the outflow from Lake Vagula.

- Additional monitoring or for the purposes of WFD, additional monitoring conducted at water points for drinking water, habitat and population reserves.

In Estonia, there are two surface water intakes used as water points for drinking water – in Tallinn, at Harju sub-basin and in Narva, at Viru project-area. Additional monitoring is required to conduct over the water point supplying Narva with drinking water 12 times a year to check the presence and quantities of all the priority substances and other substances discharged in notable quantities, possibly affecting the status of water body and that need to be checked according to the provisions stated in the Drinking Water Directive.

According to the legislation in force and the raw and drinking water inspection plan applied by AS Narva Vesi, approximately 20 indicators are under permanent control at the water intake; the frequency for sampling remains between 1 sample per hour to 1 sample per month.

As for habitat and population reserve, Nature 2000 areas are subject to additional control if the assessment of environmental impacts and monitoring for inspection purposes show that they may not meet the environmental objectives established under Article 4 of WFD.

For the development of realistic water resource management plans, based on real life requirements and preparation of expedient and rational investment plans we need to make environmental monitoring more efficient, establishing environmental monitoring at regional, county level besides environmental monitoring carried out by state and undertaking. Where it regards to aquatic environment, this should mean coordinated catchment monitoring; respective plans are drawn up by county environmental departments. Respective data is recorded in environmental register.

Catchment monitoring represents one form of environmental monitoring, organised by county environmental departments on county level, that should:

- provide information for water resource management plans, assessment, planning and implementation of environment protection measures according to their priority,
- provide a picture of the status of the environment.

Environmental monitoring conducted by an undertaking is a part of monitoring of catchment, receiving body of water, conducted by an undertaking within the scope and according the regulations provided in Environmental Register Act (§ 2, sub-section 2, clause 1 Of the Environmental Register Act). The area affected by the activities of an undertaking or by pollutants discharged into the environment as a result of such activities shall be determined in the natural resources exploitation permit or the pollution permit (Environmental Monitoring Act § 5).

COUNCIL DIRECTIVE 91/271/EEC concerning urban waste-water treatment, amended with directive 98/15/EEC, concerns the collection, treatment and discharge of urban waste water and the treatment and discharge of waste water from certain industrial sectors. The objective of the Directive is to protect the environment from the adverse effects of the abovementioned waste-water discharges.

Treatment of urban waste-water takes place by a process generally involving biological treatment with a secondary settlement or other process in which the requirements established in the Directive are respected. It is also allowed to apply other appropriate treatment of urban waste-water by any process and/or disposal system, which after discharge allows the receiving waters to meet the relevant quality objectives and the relevant provisions of this and other Community Directives.

Article 15, sub-section 2 of the Urban Waste Water Directive states that competent authorities or appropriate bodies shall monitor waters subject to discharges from urban waste water treatment plants and direct discharges as described in cases where it can be expected that the receiving environment will be significantly affected.

According to Article 5 of the Directive the Member States shall designate areas sensitive and less sensitive to pollution according to the criteria laid down in UWWTD.

As specified in Urban Waste Water Treatment Directive and Government or the Republic regulation No 269 of July 31, 2001 – Procedure for Discharging Waste Water to Water Bodies or into Soil (amended with regulation no 327 of 19.12.2003) – undertaking's obligation to conduct environmental self-monitoring should be applied in settlements where the pollution load exceeds 2,000 population equivalents. There are 46 settlements matching this criterion in Estonia, 18 of them in Viru-Peipsi project-area. According to the Urban Waste Water Directive, there are 9 settlements in Viru-Peipsi project-area with pollution load from 2 – 10,000 population equivalents, these agglomerations being: Aseri, Kadrina, Väike-Maarja, Tamsalu, Räpina, Otepää, Elva, Kunda, Jõgeva. There is one agglomeration with pollution load from 10,000 to 15 000 population equivalent, namely Võru. The remaining 8 agglomerations: Põltsamaa, Rakvere, Ahtme, Sillamäe, Põlva, Kohtla-Järve (incl. Püssi, Jõhvi, Kiviõli), Tartu and Narva (incl. Narva-Jõesuu) have a pollution load from 15,000 to 150 000 population equivalents.

Estonia's territory has been identified as sensitive in whole for reporting purposes defined in the Urban Waste Water Directive.

### **Self-monitoring conducted by water undertakings in Viru-Peipsi project-area when discharging their waste water to estuaries**

In Estonia, the Environmental Monitoring Act makes a distinction by national environmental monitoring, environmental monitoring carried out by local government and environmental monitoring carried out by undertaking.

National environmental monitoring is organised by the Ministry of Environment; monitoring is conducted under a programme endorsed by the Minister of Environment.

Local government is expected to conduct environmental monitoring to discharge its functions, defined by law or to organise its work. Environmental monitoring, carried out by local government, is based on environmental monitoring programme of a rural municipality or municipality. Local government establishes the procedure for the implementation of environmental monitoring programme.

An undertaking shall carry out environmental monitoring at the expense of the undertaking in the area affected by its activities or by pollutants discharged into the environment as a result of its activities:

- for the undertakings own purposes, if so desired;
- to the extent and pursuant to the procedure determined in the natural resources exploitation permit or the pollution permit issued to the undertaking pursuant to law;
- data from environmental monitoring carried out pursuant to a natural resources exploitation permit or a pollution permit shall be submitted by the undertaking to the issuer of the permit on the date specified in the permit.

Water Act. § 8. Special use of water. According to subsection (2) of this Article, for the special use of water, a user shall hold a permit if waste-water or other water pollutants are discharged to a recipient. § 21. Water users are required to estimate the amount and characteristics of the water used and the waste-water in the case of the special use of water and organise monitoring of the effluent under the conditions and pursuant to the procedure determined in the permit for the special use of water.

§ 23 – Obligations concerning water protection – states that a person who arranges an activity that adversely affects water quality is required to observe the water status in the area affected by the activity.

Requirements applying to monitoring and accounting of water and data transfer are specified by the issuing entity in the permit for special use of water. Regulation of the Minister of Environment No 18 - Procedure for Issue, Amendment and Revocation of Special Water Use Permits and Temporary Special Water Use Permits, List of Documents to Accompany the Application for Permit and Formats of Permits – requires the entity issuing the permit (county environmental service, as a rule) to mark the permit for special use of water with the requirement to carry out monitoring over pollutants and quality of estuary and monitoring requirements.

§ 3 of the Regulation of the Minister of Environment No 132 of November 18, 2004, Establishment of Environmental Permits Information System and the Statutes of Environmental Permits Information System, states that the objective for the establishment of the information system is to provide for a digital working environment for the processing of information required for processing applications for environmental permits and issue of environmental permits and organising work related to use of environment at state authorities.

Environmental permits are kept in web-based environmental permits information system KLIS at <http://klis.envir.ee/klis/>

Table. Excerpt of environmental permits information system KLIS, concerning permits for special use of water issued to settlements with a pollution load exceeding 2,000 population equivalents at Viru-Peipsi project-area:

Settlement	Undertaking	Requirements to pollutant monitoring applying to outlet			Quality and monitoring requirements applying to recipient		
		Place	Indicator	Frequency	Place	Indicator	Frequency
Aseri	OÜ Aseri Kommunaal	Aseri WWTP OL	BOD <sub>7</sub> , COD, P <sub>tot</sub> , N <sub>tot</sub> , HA, SO <sub>4</sub> , pH, oil products	1x per month 1x per quarter	-	-	-
Kadrina	Kadrina Soojus AS	Kadrina WWTP OL	BOD <sub>7</sub> , COD, P <sub>tot</sub> , N <sub>tot</sub> , SS, SO <sub>4</sub> , pH	1x per quarter	-	-	-
Väike-Maarja	Pandivere Vesi	Väike-Maarja WWTP OL	Permit was not found in KLIS				
Tamsalu	AS Tamsalu Vesi	Tamsalu WWTP OL	-	-	-	-	-
Räpina	Revekor AS	Räpina WWTP OL	BOD <sub>7</sub> , P <sub>tot</sub> , N <sub>tot</sub> , SS	1x per quarter	-	-	-
Otepää	AS Otepää Veevärk	Otepää WWTP OL	BOD <sub>7</sub> , P <sub>tot</sub> , N <sub>tot</sub> , SS	1x per quarter	-	-	-
Elva	OÜ aqua & waste services	Elva WWTP OL	BOD <sub>7</sub> , COD, P <sub>tot</sub> , N <sub>tot</sub> , SS, SO <sub>4</sub> , pH	1x per quarter	-	-	-
Kunda	Kunda Vesi AS	Kunda WWTP OL	Permit was not found in KLIS				
Jõgeva	OÜ Jõgeva Vesi	Jõgeva WWTP OL	BOD <sub>7</sub> , P <sub>tot</sub> , N <sub>tot</sub> , SS,	1x per month	-	-	-
Põltsamaa	OÜ Melior	Põltsamaa WWTP post-treatment facility OL	BOD <sub>7</sub> , P <sub>tot</sub> , N <sub>tot</sub> , SS,	1x per month	On the border between town and rural municipality	BOD <sub>7</sub> , P <sub>tot</sub> , N <sub>tot</sub> , HA,	1 per quarter
Ahtme	Viru Vesi AS	Ahtme WWTP OL	Permit was not found in KLIS				
Sillamäe	AS Sillamäe Veevärk	Sillamäe WWTP OL	BOD <sub>7</sub> , COD, P <sub>tot</sub> , N <sub>tot</sub> , SS, SO <sub>4</sub> , pH, oil products, Fe, Cl, F, Zn, Mo, Cr, Cu, Mn, Sr, Cd, Co, Al, W	1x per week  2 x per quarter	-	-	-

Põlva	Põlva Reo- vee-puhasti AS	Põlva WWTP OL	BOD <sub>7</sub> , P <sub>tot</sub> , N <sub>tot</sub> , SS, SO <sub>4</sub> , pH COD	1x per quar- ter 2x per year	-	-	-
Võru	Võru Vesi AS	Võru WWTP IL and OL	BOD <sub>7</sub> , P <sub>tot</sub> , N <sub>tot</sub> , SS, SO <sub>4</sub> , pH COD	1x per quar- ter 2x per year	River Võhand u 30 m upwards and down- wards from OL	BOD <sub>7</sub> , P <sub>tot</sub> , N <sub>tot</sub>	2x per year
Kohtla-Järve	Viru Vesi AS	Kohtla- Järve regional WWTP OL	Permit was not found in KLIS				
Tartu	Tartu Vee- värk AS	Tartu WWTP IL and OL	BOD <sub>7</sub> , COD, P <sub>tot</sub> , N <sub>tot</sub> , SS, SO <sub>4</sub> , pH oil products Cd, Cr, Cu, Hg, Ni, Pb, Zn	Every day  1x per quar- ter	Emajõgi - Ranna, Kvis- sental, Sõpruse bridge, Ropka, Ihaste, Luunja	At least taxable components -BOD <sub>7</sub> , COD, SO <sub>4</sub> , N <sub>tot</sub> , P <sub>tot</sub> , SS, oil products	3x per year
Narva	AS Narva Vesi	Narva WWTP IL and OL	pH, dissolved O <sub>2</sub> , tempera- ture, SS, con- ductivity, sulphides, dry waste, chlo- rides, BOD <sub>7</sub> , COD, P <sub>tot</sub> , N <sub>tot</sub> , SO <sub>4</sub> oil products, 1- al and 2-al phenols, ni- trates, nitrites, Cd, total Cr, Cu, Hg, Ni, Pb, Zn	1x per day  1x per month  2x per month  1x per quar- ter	100 m upflow and 300 m down- flow from WWTP OL	pH, dis- solved O <sub>2</sub> , temperature, HA, conduc- tivity, sulphides, dry waste, chlorides, BOD <sub>7</sub> , COD, P <sub>tot</sub> , N <sub>tot</sub> , NH <sub>4</sub> , SO <sub>4</sub> , Oil prod- ucts, 1-al and 2-al phenols, nitrates, nitrites, Cd, total Cr, Cu, Hg, Ni, Pb, Zn	2x per year in spring and autumn

Abbreviations used

WWTP – waste water treatment plant

IL - inlet

OL – outlet

SS – suspended solids

## Results of screening of permits for special use of water

Search from environmental permits information system (KLIS) did not show the permits for special use of water of five water undertakings serving the settlements of Väike-Maarja, Kunda, Rakvere, Ahtme and Kohtla-Järve.

Requirements for monitoring of pollutants, specified on permits for special use of water of 12 water undertakings found on KLIS meet the Regulation of the Government of the Republic No 269 of July 31, 2001, *Procedure for Discharging Waste water to Water Bodies or into Soil*, stating that special user of water is required to assure taking of samples from outlets determined in permit for special use of water and organise the analysis of samples for checking the limit values of waste water pollution indicators or treatment levels of waste water. Samples must also be taken by attested samplers and analysed in accredited laboratories as provided in legislation in force in Estonia.

The sampling frequency is 12 samples per year in case of the pollution load from a source of pollution being 1,999 – 49,999 population equivalents and 24 samples per year if the pollution load origination from a source of pollution exceeds 49,999 population equivalents.

If pollution load originating from a source of pollution remains between 2,000 – 9,999 population equivalents and all the 12 samples, taken of waste water over the first year, show values remaining within the range provided by limits, at least 4 samples per year must be taken. If indicators detected even in one of the samples taken from waste water exceed the limit values, 12 samples per year must be taken again.

The part concerning quality of recipient and monitoring requirements is completed to different extent or not specified at all by the authorities having issued the permits. Determination of quality of recipient is required in four permits out of twelve, the required frequency being from two to four times per year. The indicators have been chosen from among the taxable pollutants, mostly BOD<sub>7</sub>, N<sub>tot</sub>, P<sub>tot</sub> etc. In two cases – respectively, Narva and Võru, monitoring has been required both upstream and downstream from the waste-water discharge. Water use annual report gives the Koreli stream, passing through the town, as the recipient of waste-water discharged from Võru waste-water treatment plant while the requirement for monitoring recipient, specified on the permit for special use of water, refers to river Võhandu – upstream and downstream of Koreli – therefore requiring some additional explanations on the permit.

The requirement to determine heavy metals at catchment has been established to control the impact given by discharge of waste water of town of Narva.

The content of heavy metals in Estonian rivers is rather low; this was affirmed by in-depth research conducted in 2000 within the framework of the national river monitoring programme as 12 samples per year were taken from eight rivers: rivers Jägala, Kasari, Keila, Kunda, Narva, Pirita, Purtse and Pärnu. There are also no immediate sources of heavy metals in Estonia. Metals are bounded in sediments in alkaline environment and at high pH. Therefore, national monitoring programme requires the determination of content of heavy metals in water once a year in 16 rivers, except in rivers Keila, Selja and Emajõgi, chosen as water bodies protected as habitat of Salmonidae and Cyprinidae and River Mustajõgi, has been chosen among transboundary watercourses for studying the impact of mining waters where monitoring is carried out six times a year (Monitoring of hydrochemical processes in rivers in 2004, Report of...).

Permits for special use of water state the aforementioned requirements concerning water discharged from waste-water treatment plants; nevertheless, not all the permits gave a clear indication of samples taken from water entering treatment plants. Requirements concerning monitoring of recipient are generally given quite insufficiently in permits for special use of water.

## **Recommendations concerning adding up self-monitoring requirements, carried out by undertaking, specified on permit for special use of water**

Considering the information provided above, pipe-end pollutant and recipient-monitoring requirements provided in permits for special use of water should be supplemented with the following as specified in legislation in force:

- Clearly defined requirement for taking samples of waste-water entering water treatment plant and determination of pollution load in this water should be added to the permit.
- Requirement for the conduct of recipient monitoring both upstream and downstream of waste-water discharge should be specified, whereas the indicators to be determined and monitoring frequency should be at least the same as for pollutants discharged from pipe-end.
- The permit should state the requirement for informing the authority having issued the permit for special use of water of the results of self-monitoring carried out on recipient.

## **Contradictions detected upon screening of legislation and references used for the drafting of this overview, requiring harmonisation**

As provided in the Urban Waste Water Directive, Estonia's territory has been identified as sensitive in whole. The regulation of the Minister of Environment, currently in force in Estonia – *Approval of List of Water Bodies Used as Waste Water Recipients of the Parts thereof Based on Their Sensitivity to Pollution* – only certain water bodies or their parts are identified as sensitive.

As specified in agreement between the Government of the Republic of Finland and the Government of the Republic Estonia on Cooperation on Water Protection, the treatment level of 90% regarding elimination of organic substance and phosphorus should be achieved in settlements with more than 2,000 inhabitants by the end of 2005. The average content of organic substance in waste water discharged to bodies of water must be  $\leq 15$  mg/l (measured by BOD<sub>7</sub>) while the average content of total phosphorus should be  $\leq 1.0$  mg/l, including emergency discharges and overflows. Regulation by the Government of the Republic, Procedure for Discharging Waste Water to Water Bodies or into Soil, the threshold for respective phosphorus indicators is higher. The treatment level for total phosphorus is higher than/equal to 80% and the respective limit value for discharge is 1.5 mg/l. The requirements stated in this regulation are in force since the beginning of 2005.

## **Recommendations for assuring better compliance with requirements stated in the Water Framework Directive, the Water Act and Water Resource Management Plans**

- The Environmental Monitoring Act should be amended to insert the level for monitoring carried out at regional (county) level.
- County environmental departments should be strengthened in such a way that they could take the additional obligation for the elaboration of regional (county) monitoring programme (including the monitoring of area affected by activities of an undertaking, carried out under environmental permit, monitoring of recipient) and its implementation.

- Development of guidelines on the basics of recipient monitoring, assuring the quality of data and its comparability with monitoring results provided by stations involved in national monitoring programme.

Implementation of requirement for monitoring of recipient as self-monitoring required of water undertaking serving a certain areas, at least in case of settlements where the pollution load is equal to or bigger than 2,000 population equivalents.

## References

- Water Framework Directive (WFD). Directive 2000/60/EC of the European Parliament and of the Council establishing a framework for Community action in the field of water policy.
- Hea tava valgla tervikmajandamisel. Praktiline abimaterjal EL veepoliitika raamdirektiivi elluviimiseks. Keskkonnajuht1/2002. ISSN-1406-3468. (Good practice for comprehensive basin management. Practical guidelines for the implementation of the EU Water Policy Framework Directive).
- Environmental permits information system at <http://klis.envir.ee/klis/>.
- The European Environment Agency's Monitoring and Information Network for Inland Waters. Technical Guidelines for Implementation, EEA Technical Report No. 7: [reports.eea.eu.int/TECH07/en/tab\\_abstract\\_RLR](http://reports.eea.eu.int/TECH07/en/tab_abstract_RLR)
- Monitoring of hydro-chemical processes in rivers in 2004. Report of Estonian Environmental Monitoring Programme. Institute of Environmental Technology of Tallinn University of Technology, 2005
- PLC-4 guidelines. HELCOM Guidelines 20/1999

# The sampling of soil and solid wastes

Anneli Joutti  
Finnish Environment Institute SYKE  
P.O.Box 140  
00251 Helsinki  
Finland  
anneli.joutti@ymparisto.fi

## Introduction

Sampling is an essential part of the environmental monitoring. The purpose for environmental monitoring is to determine the concentration of contaminants in comparison to background levels, to determine the potential risk of contaminants to the environment or to identify pollutant sources and routes. Sampling is an essential part of this environmental monitoring. The importance of a representative soil sample prior to laboratory preparation, extraction, analysis and interpretation of results is readily apparent. Proper sampling is the important step for obtaining reliable environmental data. (cf. e.g.: <http://www.tucson.ars.ag.gov/isco/isco13/PAPERS%20A-E/BLUM.pdf>).

The problem facing samplers is that the sampling required for monitoring very heterogeneous media, such as contaminated soil and solid waste samples, is a particularly complicated process (1-3). The behaviour of contaminants depends on the properties of these samples (texture, particle size, permeability, organic content, temperature) and the properties of chemical compounds (chemical structure, solubility, viscosity etc). The variability of soil and waste samples makes sampling difficult.

In the past, major emphasis has been placed on the analytical laboratory work. However, for monitoring soil or wastes, the sampling component of variance exceeds the analysis component. For instance, the examination of the results of a components of variance analysis from a site sampled for PCBs (4) indicated that 92 % of the total variation came from the location of the sample and only 8 % was introduced after the sample was taken. As a result, less than 1 % of the total could be attributed to the analytical process itself. Thus, analytical error is a very small portion of the total variance in the testing scheme.

“There should be a balance between the soil investigation method, the quality of the soil samples and the care and skill spent on the preparation and testing of the samples. There is no point in spending time and money on careful sample preparation and testing if the quality of the samples is poor” (1).

## Sampling plan

Experience has indicated that there can be a large amount of variability between samples collected from the same soil site. It is important to collect the samples as specified by a sampling plan. A sampling plan should be designed so as to clearly define project, such as responsibilities, maximize safety, minimize time and cost, reduce error, protect sample integrity and document the representativeness of the data (ISO 16133:2004; USEPA 1996). A sampling plan should include the following:

- Goals and objectives. To ensure that a plan generates the information required of the effort, it should be developed and implemented with a clear understanding of its goals and objectives;
- Health and safety aspects;
- Site evaluation. Any sampling activity is improved by examining what is known about a site. This review should include the site characteristics that may impact distribution of the constituents of concern and factors that may impact implementation of the plan;
- Methods for sampling and analysis. To ensure that the data generated meets the goals and objectives for the effort, the plan should include all relevant specifications for documentation, sample locations, sample descriptions, sampling technique, sample handling, sample analysis, quality assurance and quality control, data presentation and report format.

The new soil monitoring/sampling standard ISO 16133:2004 gives detailed guidance on the sampling plan, the selection of monitoring sites, on site design, soil and site description, sampling procedures, etc. ISO/TC 190/SC 2 “Soil sampling” has also other good standards for sampling techniques, sample handling, safety and other sampling purposes. (<http://www.iso.org/iso/en/stdsdevelopment/tc/tclist/TechnicalCommitteeDetailPage.TechnicalCommitteeDetail?COMMID=4386>).

CEN/TC 292 Characterization of wastes has also new standards for sampling and sampling plan (see [http://www.standard.no/pronorm-3/data/f/0/02/21/7\\_2401\\_0/252.pdf](http://www.standard.no/pronorm-3/data/f/0/02/21/7_2401_0/252.pdf)).

## **Other standards and guidelines for sampling**

There are also other international (i.e. ISO, CEN, OECD) or national standards and guidelines (i.e. DIN, NEN, EPA, ASTM) for soil or waste sampling (see References). Because sampling depends on project objectives, sources of contamination, transport rates and biological, physical or chemical transformations of contaminants etc., no single sampling method can be recommended. Sampling personnel have to select the method that best accommodates their sampling needs.

## **The certificate programme for environmental sampling**

Theoretical standards are often insufficient for practical sampling procedures in the field. Thus, new systems and procedures are needed for environmental sampling. Quality control procedures have already been suggested, for instance water sampling in Finland, but none is yet implemented. Accreditation of sampling is used in some countries but it is a very complicated and expensive system

With this in mind, we thought in Finland that one way to improve the quality of soil/waste and other environmental sampling was to establish a personnel certification system and to require environmental sampling to be done by certified samplers. The certificate programme for environmental sampling is an independent certification system (5,6) for people working in environmental sampling, measuring and observing.

The system offers certificates to those who have at least two years practical experience on sampling in the field and who have participated in theory-based training courses in specific areas. The applicant can receive a certificate of competence also for soil and waste sampling. Certified samplers are required to demonstrate that they are both maintaining and updating their knowledge and expertise.

At the moment (7/2005) 392 people have received certification of competence in environmental sampling. To date, 40 % approved certificates have been awarded in the field of soil and waste sampling.

## References

- [1] EPA. Preparation of Soil Sampling Protocols: Sampling Technologies and Strategies "EPA/600/R-92/128) July 1992.
- [2] EPA. Soil Screening Guidance (EPA/540/R-96/018) July 1996 User's Guide.
- [3] EPA 1990. Technical Background Document ("A Rationale for the Assessment of Errors in the Sampling of Soils") (EPA/600/R-90/013) May 1990.
- [4] D.S. Barth, B.J. Mason, T.H. Starks and K.W. Brown, Soil Sampling Quality Assurance User's Guide. Second Edition. Environmental Monitoring and Support Laboratory, U.S. Environmental Protection Agency, Las Vegas, 1989.
- [5] ISO/IEC FDIS 17024, Conformity assessment – General requirements for bodies operating certification of persons .
- [6] ISO/IEC 17025: 1999, General requirements for the competences of testing and calibration laboratories.

### Standards or projects of ISO/TC 190 Soil quality/SC 2 Sampling

- ISO 10381-2:2002 Soil quality -- Sampling -- Part 2: Guidance on sampling techniques
- ISO 10381-3:2001 Soil quality -- Sampling -- Part 3: Guidance on safety
- ISO 10381-6:1993 Soil quality -- Sampling -- Part 6: Guidance on the collection, handling and storage of soil for the assessment of aerobic microbial processes in the laboratory
- ISO 10381-1 Soil quality -- Sampling -- Part 1: Guidance on the design of sampling programmes
- ISO/FDIS 10381-4 Soil quality -- Sampling -- Part 4: Guidance on the procedure for investigation of natural, near-natural and cultivated sites
- ISO/DIS 10381-5 Soil quality -- Sampling -- Part 5: Guidance on investigation of soil contamination of urban and industrial sites
- ISO/CD 10381-7 Soil quality -- Sampling -- Part 7: Guidance on the investigation and sampling of soil gas
- ISO/CD 10381-8 Soil quality -- Sampling -- Part 8: Guidance on the sampling of stockpiles

### Guidelines of TC 190/SC 7 Soil and site assessment

- ISO/DIS 15175 Soil quality -- Characterization of soil related to groundwater protection
- ISO 15176 Soil quality -- Characterization of excavated soil and other soil materials intended for re-use
- ISO/FDIS 15799 Soil quality -- Guidance on the ecotoxicological characterization of soils and soil materials
- ISO/DIS 15800 Soil quality -- Characterization of soil with respect to human exposure
- ISO/DIS 16133 Soil quality -- Guidance on the establishment and maintenance of monitoring programmes
- ISO/CD 19258 Soil quality -- Guidance on the determination of soil background values

### CEN/TC 292 Characterization of waste, WG1 Sampling

- Characterization of waste – Sampling of liquid and granular waste materials including pasta-like materials and sludges
  - ✓ Part 1: Framework for sampling plan preparation
  - ✓ Part 2: Selection and application of criteria for sampling under various condition
  - ✓ Part 3: Sampling techniques
  - ✓ Part 4: Sample pre-treatment in the field
  - ✓ Part 5: Procedures for sample packaging, storage, preservation, transport and delivery

## **EPA and soil/waste sampling methods**

- "Preparation of Soil Sampling Protocols: Sampling Technologies and Strategies" (EPA/600/R-92/128) July 1992 (Adobe PDF format, 169 pages, 2.5 Mbytes) Soil Screening Guidance (EPA/540/R-96/018) July 1996 User's Guide (Adobe PDF format, 89 pages, 1.1 Mbytes)
- Technical Background Document (Adobe PDF format, 437 pages, 5.2 Mbytes)
- "A Rationale for the Assessment of Errors in the Sampling of Soils" (EPA/600/R-90/013) May 1990 (Adobe PDF format, 65 pages, 499 Kbytes)
- Sampling Plan (Chapter 9 in EPA's official compendium of analytical and sampling methods, "SW-846")
- Waste Sampling Draft Technical Guidance 10/2002, Summary of RCRA regulatory drivers for waste sampling and analysis, Guidance on project planning using the Data Quality Objectives (DQO) Process, Expanded discussion of sampling designs, composite sampling and "hot spot" detection, Methods for characterizing heterogeneous wastes, Subsampling techniques for the field and laboratory, Expanded and updated data assessment methods, Data quality assessment
- Selecting sampling devices and tools EPA30-D-02-002: Device selection guide: RCRA Waste Sampling Draft Technical Guidance." pp. 109.-121.

# Quality control in hydrological monitoring

Markku Puupponen  
 Finnish Environment Institute SYKE  
 P.O.Box 140  
 00251 Helsinki  
 Finland  
 markku.puupponen@ymparisto.fi

## Abstract

First, some background information was given. This part comprised an overview of hydrological services in Finnish Environment Institute SYKE, which can be divided to following activities:

- ✓ Geoinformation (GIS) on water resources
- ✓ Monitoring (national hydrological programmes)
- ✓ Watershed simulation and forecasting (modelling)
- ✓ Database and data services
- ✓ Hydrological analyses and research

In this background information also the main hydrological monitoring operators and networks in Finland were presented:

- SYKE – national monitoring programmes
  - ✓ 10 networks - 1,400 stations / research basins
  - ✓ stations owned by SYKE and "water industry"
  - ✓ continuous / long-term programmes
- Regional Centres of the Environmental Administration
  - ✓ 13 regional networks on surface water level / discharge
  - ✓ 1,500 stations
  - ✓ both long-term and short-term monitoring
- Water industry (hydro power, water supply, ...)
  - ✓ monitoring related to project operation
  - ✓ estimated overall volume 700 stations

The structure of the national hydrological monitoring programme was shortly presented:

NETWORK	NUMBER OF STATIONS		
	SYKE	OTHERS	SUM
<i>HYDROMETEOROLOGICAL</i>			
Precipitation	50	400	450
Snow water equivalent	160	-	160
Evaporation (Class A)	10	10	20
<i>SURFACE WATER</i>			
Water level	225	90	315
Discharge	175	110	285
Ice thickness	45	-	45
Water temperature	40	-	40
<i>HYDROGEOLOGICAL</i>			
Groundwater basins	50	-	50
Ground frost	45	-	45

The activities of the national hydrological monitoring system have been divided within the administration as follows:

- SYKE (National Hydrological Service) takes care of
  - ✓ Network design
  - ✓ Standards
  - ✓ Data processing, database
  - ✓ Data service (national)
- Regional Environment Centres (13) take care of:
  - ✓ Observer employment and control
  - ✓ Field operation and maintenance
  - ✓ Field measurements
  - ✓ Data service (regional)

Main tools used for quality control, are:

- ✓ Hydrological quality system – available on the Intranet
- ✓ Standards (ISO, CEN)
- ✓ Courses on field operations
- ✓ Courses on primary quality control
- ✓ Individual training in the field

The structure of the quality system for hydrological monitoring is as follows:

- ✓ Home page – network menu
  - Surface water level and discharge, water temperature, snow, ice
- ✓ Main process menu
  - Objectives, actions, documents, references, updates
- ✓ Sub process menu
  - Objectives, actions, documents, references, updates
- ✓ Forms, figures, tables, instructions

The second part of the presentation was demonstration of the quality system for hydrological monitoring. This is a web based, dynamic system, that is available on the Intranet of the Environmental Administration.

The system became operational in 2000, and since that it has been developed and its contents have been extended. The main users of the system are SYKE (the coordinator, responsible for standards) and 13 Regional Environment Centres (responsible for field operations related to the national hydrological monitoring programme). So far, the system has been considered to be very successful. Updated forms, photographs and instructions in text form can easily be added into the system.

# Introduction to the biological elements of EU Water Framework Directive; phytoplankton as an example in ecological classification

Pertti Heinonen  
Finnish Environment Institute SYKE  
P.O.Box 140  
00251 Helsinki  
Finland  
pertti.heinonen@ymparisto.fi

## Introduction to the EU Water Framework Directive (WFD)

Early European water legislation began, in a "first wave", with standards for those of rivers and lakes used for drinking water abstraction in 1975, and culminated in 1980 in setting binding quality targets for drinking water. It also included quality objective legislation on fish waters, shellfish waters, bathing waters and groundwaters. Its main emission control element was the Dangerous Substances Directive.

In 1988 the Frankfurt ministerial seminar on water reviewed the existing legislation and identified a number of improvements that could be made and gaps that could be filled. This resulted in the second phase of water legislation, the first results of this were, in 1991, the adoption of the Urban Waste Water Treatment Directive, providing for secondary (biological) waste water treatment, and even more stringent treatment where necessary. The Nitrates Directive, addressing water pollution by nitrates from agriculture.

Other legislative results of these developments were Commission proposals for action on the new Drinking Water Directive, reviewing the quality standards and, where necessary, tightening them (adopted November 1998), and Directive for Integrated Pollution and Prevention Control (IPPC), adopted in 1996, addressing pollution from large industrial installations.

Water Framework Directive 2000/60/EC of 23 Oct, 2000 (establishing a framework for Community action in the field of water policy) entered into force 22 Dec, 2000.

(WFD in internet: [http://europa.eu.int/comm/environment/water/water-framework/index\\_en.html](http://europa.eu.int/comm/environment/water/water-framework/index_en.html))

## "Good ecological status"

The target of WFD is that all European surface water bodies should be in good ecological status at the end of 2015. Good ecological status is defined in Annex V of the Water Framework, in terms of

- the quality of the biological community
- the hydrological characteristics and
- the chemical characteristics.

This is the basis, that we need a lot of biological material in implementing the WFD, and especially the classification of surface water bodies. Therefore we have to organise the monitoring programmes (starting at the end of 2006) so, that we are capable to classify all the important water bodies.

In the first ecological classification of lakes we, according to the WFD, need reliable data from following hydrobiological characteristics during several years:

- Phytoplankton
- Macrophytes
- Phytobenthos
- Benthic invertebrates
- Fish

Every Member State (MS) has to develop its own classification scheme during 2004-2005, which in 2006 will be harmonised in the intercalibration process. The Joint Research Centre has established the "European Centre for Ecological Water Quality and Intercalibration" (EEWAI) which is leading an activity aiming at comparing the different national classification systems for ecological status assessment.

## The biological quality elements

In WFD the quality elements have been proposed for both rivers and lakes. The biological quality elements for the classification of ecological status of rivers are as follows:

- Composition and abundance of aquatic flora
- Composition and abundance of benthic invertebrate fauna
- Composition, abundance and age structure of fish fauna

The biological quality elements to be used for the classification of ecological status of lakes are the follows:

- Composition, abundance and biomass of phytoplankton
- Composition and abundance of other aquatic flora
- Composition and abundance of benthic invertebrate fauna
- Composition, abundance and age structure of fish fauna

## Some preliminary ideas to use phytoplankton data in ecological classification

According to the WFD the characteristics of phytoplankton in ecological classification have been determined to be the following ones:

- Species composition (can be determined only by microscopy)
- Species abundance (can be determined only by microscopy)
- Biomass (chlorophyll *a* determination or calculation from microscopy results)

In Finland a classification scheme based on the biomass (determined by microscopy) has been developed already more than 20 years ago (Heinonen 1980). According to this eutrophication classification the lakes can be grouped into five groups as follows:

1. Oligotrophic: < 0.50 mg/L ("High status" compared to the WFD terminology)
2. Incipient eutrophy: 0.51-1.00 mg/L ("Good status")
3. Mesotrophy: 1.01-2.50 mg/L ("Moderate status")
4. Eutrophy: 2.51-10.0 mg/L ("Poor status")
5. Hypereutrophy: > 10.0 mg/L ("Bad status").

The only classification factor in this grouping has been the wet weight of phytoplankton estimated from the microscopy counting. Any typology factors have not been used. So, in the Group 3 (mesot-

rophy) there might be some lakes, which naturally belong to the eutrophic lake type. The dystrophy of Finnish lakes can also affect on the phytoplankton amounts. So, this is not the final material for making any long-term conclusions.

The lakes, from which we had enough phytoplankton data at the end of 1970s (altogether 826 lakes), we could make the following summary (Figure 1):

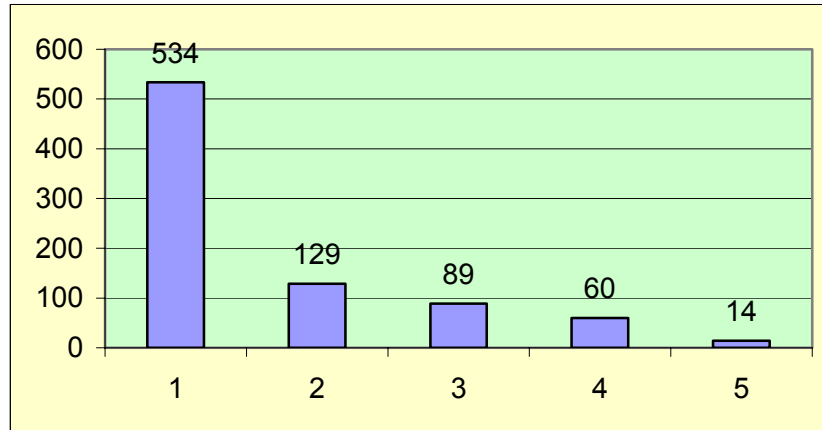

Figure 1. The number of lakes in different groups (n = 826)

Most of the lakes, which have been monitored, had so low quantity of phytoplankton (counted by microscopy from the samples taken in July), that they could be determined to be oligotrophic lakes.

This grouping has been used in the following assessment so, that Group 1 corresponds the "High status" according to the WFD terminology (Group 2 "Good status", Group 3 "Moderate status", Group 4 "Poor status", and Group 5 "Bad status"). Some characteristics, which are indicative for eutrophication, have been calculated from the whole (n = 826 lakes) material. Other information presented of the use of phytoplankton in lake classification has also been used (cf. e.g. Heinonen et al. 2000). In Figure 2, the amount of blue-green algae have been presented.

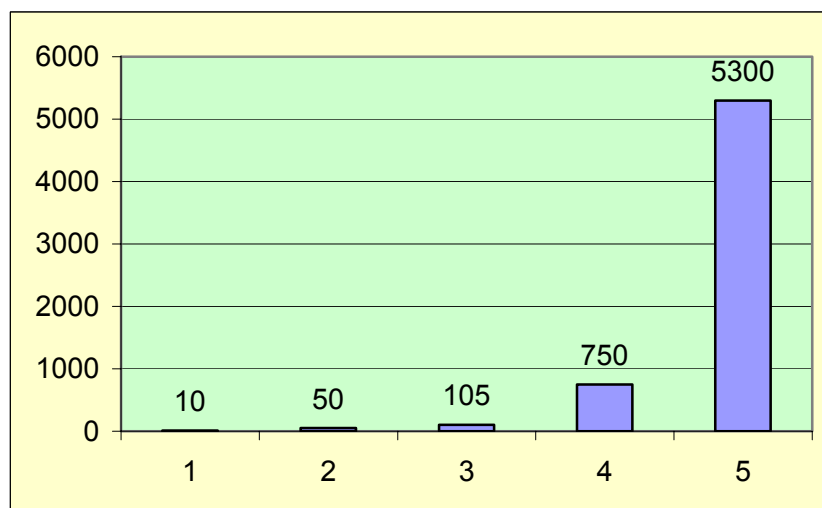

Figure 2. The amount of blue-green algae in different groups (µg/L ww)

This characteristics seems to be very sensitive one, and the Group 3 is clearly different from Groups 1 and 2. The same situation can be found from the two following characteristics, the amount of Hormogonales (Figure 3), and the amount of Protococcales (Figure 4).

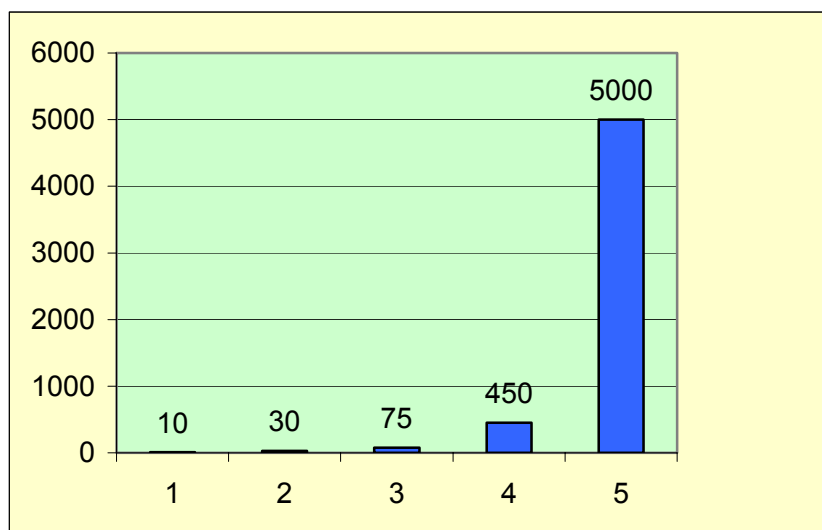

Figure 3. The amount of Hormogonales in different groups (µg/L ww)

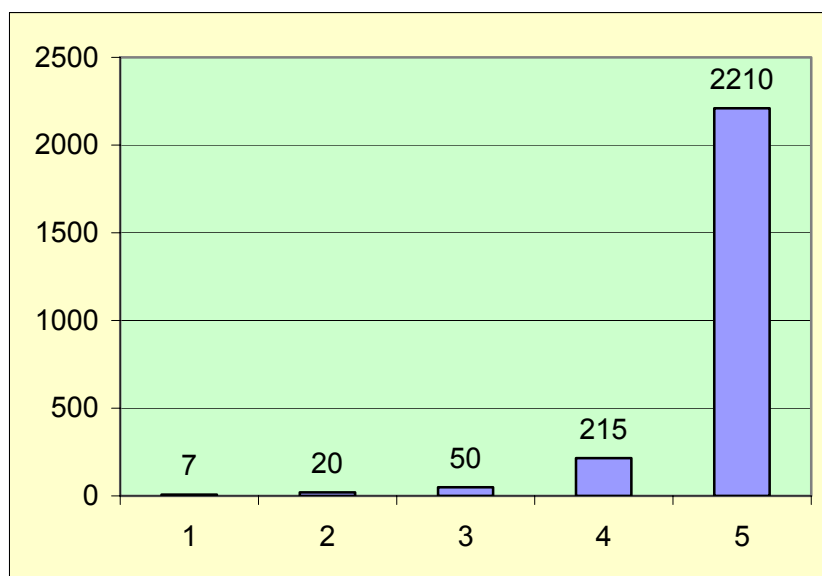

Figure 4. The amount of Protococcales in different groups (µg/L ww)

The indicators based on the occurrence of Euglenophyta-species, have the same trend. When the eutrophication of the lake increases, the number of Euglenophyta-species (as well as the total volume of Euglenophyta) also increases (Figure 5).

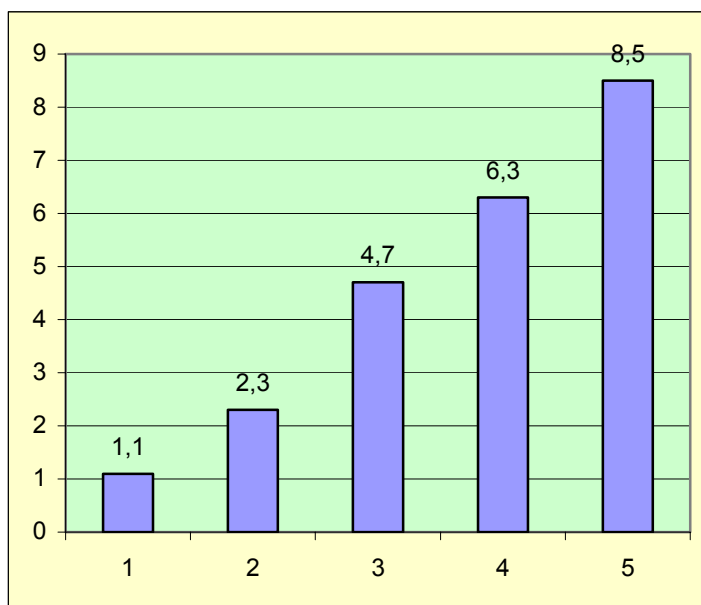

Figure 5. The number of Euglenophyta-species in different groups

One very promising indicator for eutrophication, which could possibly be used in classification of the ecological status of lakes in the implementation of the WFD, is the amount of the so called odour inducing algae (Heinonen 1980). A lot of development is, however, needed to get this indicator more practical, and more reliable.

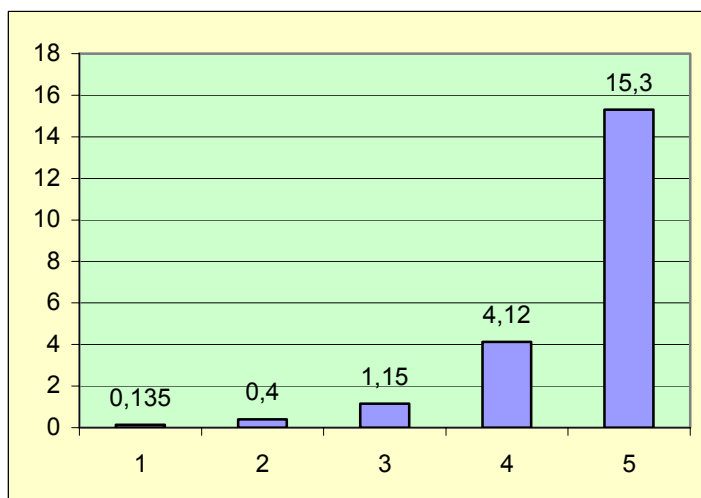

Figure 6. The amount of odour inducing algae in different groups (µg/L ww)

## Short conclusion

The figures presented in the text are only very preliminary assessments from an old phytoplankton material. The results, however, show, that there are certain possibilities to develop the indicator system based on different species and their occurrence in samples for ecological classification, but a lot of research and testing is needed.

The microscopy method is very laborious one, and also the natural variations of phytoplankton in lakes can be significant. So, assessment of total phytoplankton biomass should be determined by large number of chlorophyll *a* –analysis.

## References

- Heinonen, P. 1980. Quantity and composition of phytoplankton in Finnish inland waters. *Vesihallitus. Vesientutkimuslaitoksen julkaisuja* 37, 1-91.
- Heinonen, P., Ziglio, G. & Van der Beken, A. (Eds.). 2000. *Hydrological and Limnological Aspects of Lake Monitoring*. John Wiley & Sons, Ltd. Chichester. ISBN 0-471-89988-7. 372 p.

# Phytoplankton as a tool to classify ecological status of lakes. Estonian experiences

Ingmar Ott  
Institute of Agriculture and Environmental Sciences  
Estonian Agricultural University  
61101 Centre for Limnology  
Rannu, Tartu County  
Estonia  
iott@zbi.ee

## Introduction

European Water Framework Directive (2000) considers phytoplankton parameters among the most sensitive quality elements in the lakes required for classification of the ecological status. Estonia is included together with Latvia and Lithuania to the Baltic ecoregion. At the moment intercalibration of the borders of quality classes is going on and all Baltic countries had joined to Central intercalibration group together with Poland, Hungary, Slovakia, Czech Republic, Germany, Denmark, United Kingdom, Netherlands, Belgium and France. Local classifications including used parameters and methods are also discussed during workshops.

Estonian classification is not completed yet and uses own experiences as well as conclusions from the international cooperation. As Baltic countries are in separate ecoregion, some peculiarities does not allow directly use experiences from the other countries. Estonian area became denuded from the glacier sheet until ca 10,000 years ago. The tectonic uprise is still in process, particularly in western part of the country. The basic rock cover of Northern, Western and Central Estonia is mainly carbonate from Ordovician and Silurian Geological Period. Southern Estonia is a region of Devonian sandstone. Nearly half of Estonian territory is covered by forests and large proportion with swamps. Due to high carbonate content and humic compounds mixotrophic lake type (Ott, Kõiv, 1999) is prevailing, not common in the other countries.

## Estonian lake typology, corresponding to the WFD requirements

The ecosystems of Estonian lake types are very diverse. According to Aare Mäemets' typology (1974, 1976, 1977), eight lake types can be found in Estonia: oligotrophic (8% of the lakes), semidystrophic (6%), dystrophic (6%), eutrophic + hypertrophic (36 - 37 %), mixotrophic (36 – 37%), siderotrophic (0.2 %), halotrophic (1.4 %), and alkalitrophic (2.6%). This typology is based on the natural accumulation type and differs in principle from the typologies that could be found in the literature between 1950s and 1990s. These typologies are strictly based on the trophic state. Under the term “accumulation type” is considered to be complex phenomena of factors mainly influencing the matter circulation of the lakes. For instance, inflow of seawater, (influence sulphate and chloride ions) as well morphometrical features are the main factors forming specific matter circulation in halotrophic lakes.

The same situation can be described in alkalitrophic lakes, where the main factor is calcareous input or in siderotrophic lakes, where mainly high content of dissolved iron creates different matter circulation from the other lake types. A specific complex of fauna and flora and a certain matter and energy circulation characterizes each lake type. Aare Mäemets worked out his classification on the

basis of data from 1951-1970. For practical reasons Mäemets' typology is difficult to use because it is too complicated and comprehensive.

Ott & Kõiv (1999) modified this typology taking into account the changes in the nature during the past decades, also some new principles. 12 types without subtypes were distinguished. The lakes are grouped in a more generalized form.

Very soon after the last published issue, WFD gave new requirements for typology and since simplicity, practicality of the system is needed, this last Estonian version was modified again (Nõges & Ott, 2003). Number of types was reduced to seven – two large lakes (Peipsi and Võrtsjärv) as separate types and five small lakes. The latter typology is presented on the Table 1.

Table 1. Estonian WFD typology for small lakes.

Type	Type N	Alkalinity, mg/l	Colour (1-10 arbitrary scale); Pt-Co °	Depth
Alkalitrophic	1	HCO <sub>3</sub> ≥ 240	-	-
Shallow, light, medium alkalinity	2	HCO <sub>3</sub> 80-240	<8; <100	not stratified
Deep, light, medium alkalinity	3	HCO <sub>3</sub> 80-240	<8; <100	stratified
Dark, soft water	4	HCO <sub>3</sub> ≤ 80	>7; ≥100	-
Light, soft water	5	HCO <sub>3</sub> ≤ 80	<8; <100	-

Still some uncertainties remained for the typology. Coastal lakes with great influence from seawater, karst lakes are not included into the system. The most important, still not decided problem is with mixotrophic, prevailing lake type. Part of these belong to the second, part to the third group.

## Estonian lake classification corresponding to the WFD requirements

WFD classification is still not completed, but the main features are selected. We use 5 abiotic, 3 phytoplanktic and macrophytic, as well as 5 zoobenthical parameters (Table 2).

Some principles were used giving final decision of the ecological quality:

- a) minimal used number of parameters is 7,
- b) all parameters have equal weight,
- c) final score is decided by limit 2/3 of used total number of characteristics, it means that 2/3 of values should fall into concrete quality class or higher.

Estonian version of the classification does not use the WFD requisition, also known as principle "one out, all out", where final score should be decided as the lowest level of parameters met during the analyses.

Table 2. Description of parameters used in Estonian WFD classification.

<b>Parameter</b>	<b>Units, description, comments</b>
Secchi disc visibility	m; is not used in lake type N 4.
pH	Is not used in soft water, dark coloured (type N 4, acidotrophic and dystrophic) lakes
Total phosphorus	mg/m <sup>3</sup> ; average from the water column
Total nitrogen	mg/m <sup>3</sup> ; average from the water column
Metalimnion range	m; metalimnion is defined as decrease of temperature or oxygen content 1.5 units per m in the water column. Is used in types N 1, 3, 5.
Concentration of chlorophyll <i>a</i>	mg/m <sup>3</sup> ; average from the water column
Phytoplankton compound quotient	Index is based on species number of indicator taxa, average from the water column
Phytoplankton community	Community is divided into 3 three indicative versions on the basis of dominating species.
Macrophyte association	Char - Communities dominated by charophytes, with vascular plant species. ElPo - Communities of elodeids and pondweeds, rooted in sediment and often abundant though with several species present, often including nymphaeids and some aggressive charophytes. CanNym - Dense communities of nymphaeids and or canopy forming poorly rooted plants like <i>Lemna trisulca</i> . This community may persist despite large phytoplankton densities. Iso - Communities dominated by isoetids ( <i>Isoetes</i> , <i>Lobelia</i> ). Mosses may also be present. Sphag - Communities dominated by <i>Sphagnum</i> , occurring in extensive swards. Alg - Low biomass, communities with aquatic mosses, filamentous desmids and zygnetatales.
Number of macrophyte taxa	Number of hydrophyte species (species without emergent plants)
Macrophyte abundance	Macrophyte abundance PVI - plant volume infested on 0-5 scale 0 – without plants 1 – some visible plants 2 – ca 25 % 3 - ca 25-50 4 - ca 50-65, main parts of plants extend to the surface of the water 5 - >65, dense plant cover and extend to the surface
EPT index for macrozoobenthos*	Ephemeroptera, Plecoptera, Trichoptera taxa richness in the littoral on May. Is used for lake types N 2, 3, 4, 5, on four substrate types
Shannon's diversity of macrozoobenthos species*	Shannon' index is based on information of abundance and species richness. Is used for lake types N 2, 3, 4, 5 on four substrate types
British Average Score Per Taxon (ASPT)*	Sum of tolerance values of indicative macrozoobenthos species. Is used for lake types N 2, 3, 4, 5 on four substrate types
Acidity index for macrozoobenthos*	Is used for lake types N 2, 3, 4, 5 on two substrate types
The number of macrozoobenthos taxa*	Is used for lake types N 2, 3, 4, 5 on three substrate types

\* for the details see H. Timm's article in the same publication. Original descriptions of the corresponding indices: Armitage *et al.*, 1983; Johnson, 1999; Lenat, 1988

## Phytoplankton characteristics, used in Estonian classification

### Compound quotient:

Modified Nygaard's (1949) phytoplankton compound quotient (PCQ) was used to characterize the ecological status of the lake. PCQ gives quite good estimation to the lake ecological condition, although algal groups in formula may contain species with different preferences. Ott & Laugaste (1996) added to the original formula 2 extra taxa: Cryptophyta to numerator and Chrysophyceae to denominator. Modified index gives more precise estimation about Estonian lakes, because the abundance of Desmidiaceae, the only taxa originally used in denominator, in open water and in littoral zone has dramatically declined during the past decades (Kangro et al., 2005).

### PCQ, modified by Ott & Laugaste (1996):

$$\text{PCQ} = \frac{\text{Cyanophyta}^* + \text{Chlorococcales}^* + \text{Centrales}^* + \text{Euglenophyceae}^* + \text{Cryptophyta}^* + 1}{\text{Desmidiaceae}^* + \text{Chrysophyceae}^* + 1}$$

\* - number of species. The trophic classification of values, modified from the original is in the Table 3.

Table 3. Trophic classification of phytoplankton compound quotient.

Trophic state	Nygaard, 1949	Ott & Laugaste, 1996
Oligotrophic	1.0	<2
Dystrophic	0 - 0.3	<2
Mesotrophic		2 - 5
Eutrophic	1.0	5 - 7
Eutrophic with organic pollution	5 - 20	
Hypertrophic		>7

This index is used in state monitoring since 1993. On the Figure 1 one can find some results. Number of lakes in each type: 1 - 62; 2 - 77; 3 - 64; 4 - 70; 5 - 86. On the basis of large database the results seem to be very good. One of the advantages to use this index is that identification to the species or even to the genus level is not needed.

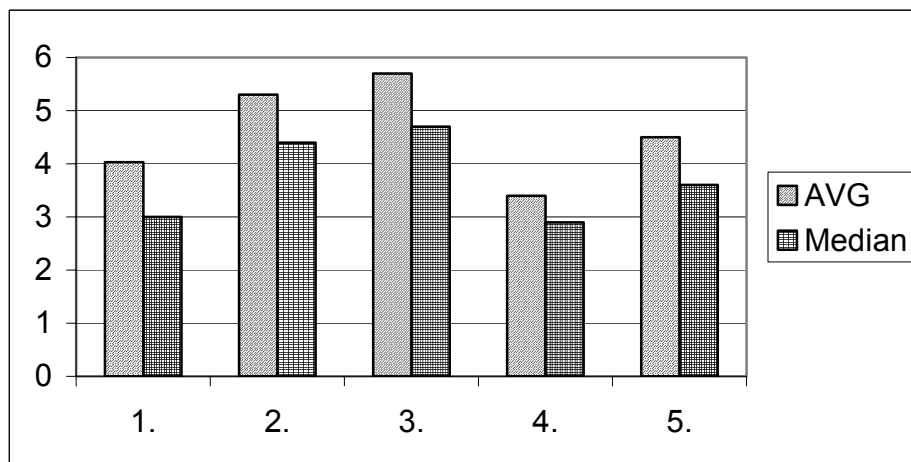

Figure 1. The values of phytoplankton compound quotient in Estonian WFD lake types. Names of the types see on the Table 1.

### Phytoplankton association:

Prevailing community gives also information about the ecological quality of the lakes. The following description is modification from Ecoframe project, where also Estonian representatives took part (Moss et al., 2003). Three different possibilities were described starting with the best quality:

- A. Abundance is more or less equal, dominating species are not well distinguished
- B. One species is prevailing in abundance (>80%)
- C. *Microcystis*, *Radiocystis*, *Woronichinia*, *Aphanizomenon*, *Anabaena*, *Planktothrix* from cyanobacteria or chlorococcales from chlorophytes prevail and chlorophyll *a* concentration is >20 mg/m<sup>3</sup>.

Prevailing algal group sometimes is complicated to distinguish since always remains the question, what is more important, abundance or biomass. Therefore better results give comparison of different species with own scale and not the species comparison at the same phytoplankton sample. Since this classification is recently proposed, proper scales need to be developed in near future.

### Concentration of chlorophyll *a*:

It is obvious that phytoplankton production or biomass are highly fluctuating characteristics. Biomass counting is complicated and time consuming. Good results can achieve using frequent sampling and for that purpose chlorophyll concentration is more suitable. Detailed guidance of counting technique is developed in Nordic countries (Oirik et al., 1998). The other countries admitted estimation of phytoplankton biovolume too complicated. Nevertheless, Estonia uses phytoplankton counting as well as concentration of chlorophyll *a* in state monitoring, but for WFD classification only the latter one is used.

Chlorophyll *a* values (Figure 2) in lake types are not so logically distributed as values of compound quotient. The main reason why relatively high values occur in soft water types is caused mainly by one species, *Gonyostomum semen*, abundant especially in mid- and late summer. Average and median values in third type are extremely different. Arithmetical average is so high due to water blooms, so often in phytoplankton prevailing lakes, while in the second type macrophytes are dominating primary producers.

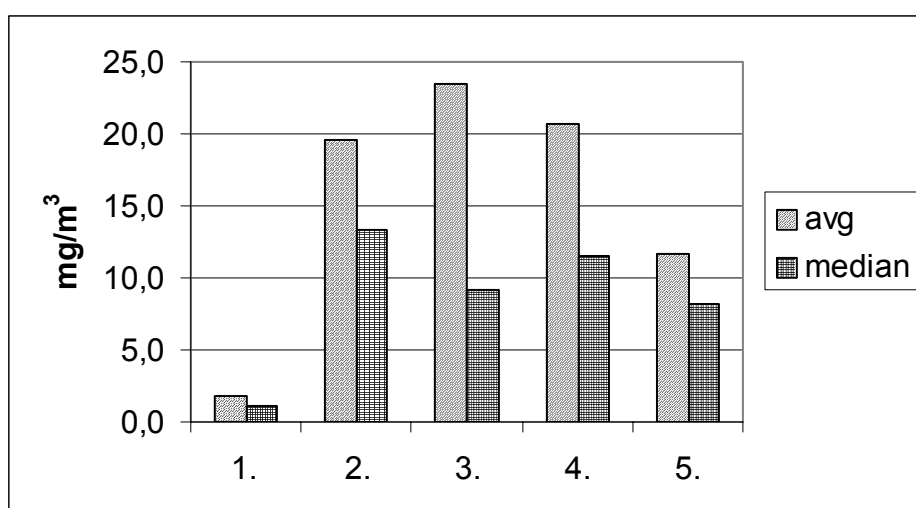

Figure 2. Chlorophyll *a* concentration in Estonian WFD lake types. Names of the types see on the Table 1. Number of lakes is the same in Figure 1.

Phytoplankton, other potential characteristics:

Indices are mainly based on species composition and therefore are more stable carrying information for a longer period in comparison with measured parameters (Willen, 2000). At the same time indices have more subjective character. Sometimes these seem to be too simplified. Numerous proposed quotients can be found from the literature, like Carlson's trophic state index (1977; based on chlorophyll a, total phosphorus and water transparency), Thunmark's (1945) and Nygaard's phytoplankton indices (1949), Järnefelt's E/O index (1952; indicator value of different taxa), odour index (Seppovaara, 1971), Shannon-Weaver's species diversity (1949; depending on number of taxa and distribution of abundance), evenness (theoretical diversity by Pielou, 1975), algal potential growth (bioassay, Leis & Toom, 1982).

This list can be continued, but we would like to pay attention E/O index, which was modified using Järnefelt's E/O index and Shannon's species diversity (Ott, 1987). Special feature is that every indicator species has its own numerical indicator value. This value is found by frequency of species in the lakes with high-good (more simple expression good) or moderate-poor-bad (bad) ecological status, correspondingly. Summing up separately indicator values of good and bad status, the final score is calculated. The following equations are used:

$$Y_{Eu(Ol) i} = \frac{1}{\frac{I_{Eu(Ol)}}{I_{Eu} + I_{Ol}} * lb \frac{I_{Eu(Ol)}}{I_{Eu} + I_{Ol}}}$$

- , where
- IEu (Ol) – finding frequency % in good or bad status lakes correspondingly
- lb – binary logarithm
- YEu (Ol) i - indicator value of species of good or bad status correspondingly

Final score (E/O) is calculated by quotient:

$$E/O = \frac{\left( \frac{\sum_{i=1}^n Y_{Eu i} + 1}{\sum_{i=1}^n Y_{Ol i} + 1} \right)}{n_1 + n_2}$$

n<sub>1</sub>, n<sub>2</sub> – number of indicator species of good and bad status

Redesign as well as use of E/O index for WFD purposes is right now in process.

Recently in the Central geographical intercalibration group was proposed by French colleague Jean Pierre Martinez (personal communication) a phytoplankton index, where the identification of algae down to the species level also is not important. Participating countries are analysing with own materials the possibility to use that index.

## French Phytoplankton Index.

### *Sampling strategy*

Three sampling periods:

- ✓ the first one in spring when the thermocline is setting up,
- ✓ the second one when the thermocline is well established during summer,
- ✓ the last one at the end of the summer stratification, before temperature drops down and stratification disappears.

All these sampling surveys should be realised during the same annual cycle.

### *Sampling technique*

Tool: Nansen type net, mesh size 10 µm, opening 30 to 40 cm.

Samples:

- ✓ one taken from the bottom to the surface
- ✓ one taken horizontally by pulling the net 1 to 2 m below the water surface on a 100 m length.

Each sample is stored in a 100 to 250 ml bottle and preserved with Lugol solution.

### *Index calculation*

An index is calculated for each sampling period according to the following formula:

Index =  $\sum Q_i \cdot A_j$  with  $Q_i$ : weighting factor (Table 4) for the different algal groups.

Table 4. Weighting factor of taxonomical groups.

<b>Algae groups</b>	<b>Qi</b>
Desmidiaceae	1
Diatomophyceae	3
Chrysophyceae	5
Dinophyceae and Cryptophyceae	9
Chlorophyceae (except Desmidiaceae)	12
Cyanophyceae	16
Euglenales	20

The relative abundance ( $A_j$ ) of the groups is presented on the table 5. These abundances were estimated by counting around 100 individuals of each sample (horizontally and vertically) by microscopic observation. For species identification, an ocular of 10 and objectives from 20 to 60 is used.

Table 5. The values of the relative abundance ( $A_j$ ).

<b>Relative abundance (%)</b>	<b>Aj</b>
0 to $\leq$ 10	0
10 to $\leq$ 30	1
30 to $\leq$ 50	2
50 to $\leq$ 70	3
70 to $\leq$ 90	4
90 to $\leq$ 100	5

The final score of the French phytoplankton index is the mean of the three indices calculated for each sampling period.

#### Phytoplankton sampling strategy

Samples are gathered in Estonian small lakes twice per year (May, July) from 2-3 layers from the water column depending on stratification. Qualitative samples with Apstein nets (mesh size 10-63 µm) are gathered by trawling and vertically from the whole water column in the deepest point of the lake.

## Microscopical analyses and methods for analyzing photosynthetic pigments

According to international recommendations inverted microscope is used for counting of algae (Utermöhl's technique). In fact, if counting is not used for classification, also other types of microscopy can be used.

96% acetone as extracting solution is used for spectrophotometric measurements and different equations for concentration calculations (Jeffrey & Humphrey, 1975; Lorenzen, 1967; Strickland & Parsons, 1972).

## References

- Armitage, P.D., Moss, D., Wright, J.F., Furse, M.T., 1983. The performance of a new biological water quality score system based on a wide range of unpolluted running-water sites. - *Water Res.* 17: 333-347
- Carlson, R. E., 1977. A trophic state index for lakes. *Limnol. Oceanogr.*, 22, 361-369.
- Jeffrey, S. W. & G. F. Humphrey, 1975. New spectrophotometric equations for determining chlorophylls a, b, c1 and c2 in higher plants, algae and natural phytoplankton. - *Biochemie und physiologie der Pflanzen* 167: 191-194
- Johnson, R.K., 1999. Benthic macroinvertebrates. In: *Bedömningsgrunder för miljökvalitet. Sjöar och vattendrag. Bakgrundsrapport 2. Biologiska parametrar* (Ed. by Torgny Wiederholm). Naturvårdsverket Förlag, 85-166.
- Järnefelt, H., 1952. Plankton als Indikator der Trophiegruppen der Seen. *Ann. Acad. Scient. Fennicae. A, IV* (18). 29 S.
- Kangro, K., Laugaste, R., Nõges, P. & I. Ott. 2005. Long-term changes and seasonal development of phytoplankton in a strongly stratified hypertrophic lake. *Hydrobiologia* 547: in press.
- Krause, T., Künnap, H., Laas, A., Lill, E., Lorens, B., Luup, H., Miracle, M.R., Nõges, P., Nõges, T., Nykänen, M., Ott, I., Peczula, W., Peeters, E.T.H.M., Phillips, G., Romo, S., Russell, V., Salujõe, J., Scheffer, M., Siewertsen, K., Smal, H., Tesch, C., Timm, H., Tuvikene, L., Tönno, I., Virro, T., Wilson, D. 2003. The determination of ecological quality in shallow lakes - a tested system (ECOFRAME) for implementation of the European Water Framework Directive. - *Aquatic Conserv: Mar. Freshw. Ecosyst.*, 13, 507-549.
- Leis, M., Toom, M., 1982. Veekogude eutrofeerumise algoloogiline hindamine. *Eesti NSV järvede nüüdisseisund. Trt. lk.* 116 – 125.
- Lenat, D. R., 1988. Water quality assessment of streams using a qualitative collection method for benthic macroinvertebrates. - *J. North Amer. Benthol. Soc.* 7, 3: 222-233.
- Lorenzen, C. J., 1967. Determination of chlorophyll and pheopigments: Spectrophotometric equations. - *Limnol. Oceanogr.* 12: 343 346
- Moss, B., Stephen, D., Alvarez, C., Becares, E., Van de Bund, W., Collings, S.E., Van Donk, E., De Eyto, E., Feldmann, T., Fernández-Aláez, C., Fernández-Aláez, M., Frankeng, R.J.M.,

- García-Criado, F., Gross, E., Gyllström, M., Hansson, L.-A., Irvine, K., Järvalt, A., Janssen, J.-P., Jeppesen, E., Kairesalo, T., Kornijów, R., Mäemets, A., 1974. On Estonian Lake Types and Main Trends of Their Evolution Estonian Wetlands and Their Life. Tallinn, p. 29-62
- Mäemets, A., 1976. Lake types as basis for the limnological division on the Estonian S.S.R.. In: Estonia. Regional Studies. Tallinn. p. 63-71.
- Mäemets, A., 1977. Eesti NSV järved ja nende kaitse. Valgus, Tallinn, 263 lk.
- Nõges, P. & I. Ott, 2003. Eesti järveteadus Euroopa tõmbetuultes. Kaasaegse ökoloogia probleemid. Eesti globaliseerivas maailmas. Eesti IX Ökoloogiakonverentsi lühiartiklid. 159-172.
- Nygaard, G., 1949. Hydrobiological studies on some Danish Ponds and lakes II. The quotient hypothesis on some new or little known phytoplankton organisms. Det Kongelige Danske Videnskabernes Selskab 7: 293 pp.
- Olrik, K., Blomqvist, P., Brettum, P., Cronberg, G., Eloranta, P., 1998. Methods for quantitative assessment of phytoplankton in freshwater, part I. Svensk Miljöövervakning. 73 pp.
- Ott, I., 1987. Long-term changes of summer phytoplankton in Estonian lakes and relations with ecological factors. Dissertation. Manuscript at Tartu University. 203 pp.
- Ott, I. & T. Kõiv, 1999. Special features and changes of Estonian small lakes. Tallinn. 127 pp.
- Ott, I. & R. Laugaste, 1996. Fütoplanktoni koondindeks (FKI), üldistus Eesti järvede kohta. Eesti Keskkonnaministeeriumi infoleht. 3: 7-8. [The Phytoplankton Compound Quotient (PCQ), generalisation about Estonian small lakes. In Estonian].
- Pielou, E.C., 1975. Ecological Diversity. New York.
- Seppovaara, O., 1971. The effect on fish of the mass development of brackish water plankton. Aqua Fennica. p. 118-129.
- Shannon, C.E. & W. Weaver, 1949. The mathematical Theory of Communication. Urbana, Univ. Illinois Press, 117 pp.
- Strickland, J.D.H. & T.R. Parsons, 1972. A practical handbook of seawater analysis. - Bull. Fish. Res. Board. Can. 167: 1-310
- Thunmark, S., 1945. Zur Sociologie des Süßwasserplanktons. Eine methodologisch-ökologische Studie. Folia Limnol. Scand. 3. 66 S.
- Willen, E., 2000. Phytoplankton in water quality assessment – an indicator concept. Hydrological and limnological aspects of lake monitoring. Heinonen, P., Ziglio, G., van der Berken, A. (eds.). 57-80

# Chlorophyll *a* as an estimate for phytoplankton in ecological classification

Sirpa Herve  
Central Finland Regional Environment Centre  
P.O.Box 110  
40101 Jyväskylä  
Finland  
sirpa.herve@ymparisto.fi

## Introduction

Phytoplankton amount is one of the most indicative determinands of the eutrophication status of lakes. This characteristic is also mentioned in EU Water Framework Directive (WFD). The phytoplankton analysis by microscopy has long traditions in monitoring of especially lakes, but it is very laborious and expensive method. It requires also high competence in identifying of the species. Therefore, some supporting and more practical analysis, which is easier to carry out, is absolutely needed.

## Chlorophyll *a*

Also chlorophyll *a* has been used for a long time as an estimate for phytoplankton amount, but chlorophyll *a* has not been mentioned in the WFD, not even in the list of supporting chemical and physico-chemical elements. It has, however, included in the CIS Guidance document 7: "Monitoring under the Water Framework Directive". In practise, most of the present routine monitoring programmes connected to eutrophication problems, have included chlorophyll *a* to the programmes. It has also been mentioned by European Environment Agency (EEA) as one of biological indicators.

There is a good correlation between chlorophyll *a* and phytoplankton biomass determined by microscopy. There is also good correlation between chlorophyll *a* and many other important indicators of eutrophication. As an example, correlation between phosphorus and chlorophyll *a* in Finnish lakes has been presented (Figure 1).

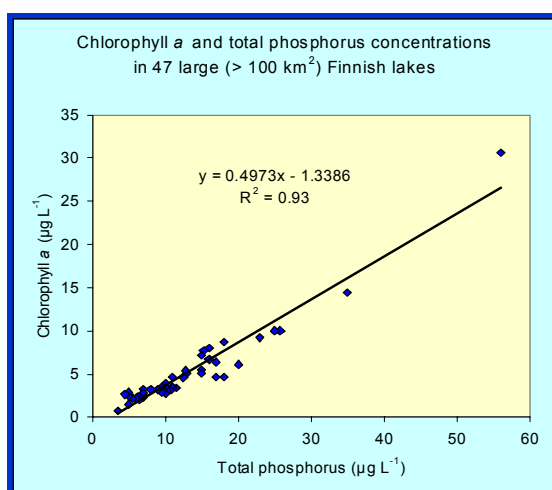

Figure 1. Correlation between the chlorophyll *a* content and the phosphorus content in Finnish large lakes (Heinonen et al. 2003)

The method has been tested for tens of years, and good national and international standards are available. The method is also practical and relatively cheap.

## Chlorophyll as a classification tool

There are many classification procedures based on the mean chlorophyll content of the growing season. The most used application in Finland has been the Finnish water quality classification since 1985 (based on usability of water bodies for different purposes). Chlorophyll criteria for general classification was the following one (Heinonen and Herve 1987):

Status of the lake for different uses	Chlorophyll <i>a</i> , µg/L (summer mean value)
excellent	< 3.0
good	3-10
moderate	10-20
poor	20-50
bad	> 50

In phytoplankton studies following classification for eutrophication of lakes have been used (Leppistö 1999)

Type of the lake	Chlorophyll <i>a</i> , µg/L (summer mean value + variation %)
Oligotrophic lakes	2.7 (V 44.4%)
Dystrophic lakes	6.2 (V 48.4%)
Mesotrophic lakes	8.7 (V 55.2%)
Eutrophic lakes	36.9 (V 81.6%)
Hypereutrophic lakes	52.4 (V 84.0%)

## Practical questions in chlorophyll *a* analysis

If chlorophyll has been added to the research or monitoring programmes, the following aspects concerning the sampling should be followed:

- Composite samples usually taken from epilimnion (0-2, 0-4 metres) in pelagic area
- Avoid the possible shore effect (not in too shallow sites, not among the macrophytes)
- Several samples during the growing season are needed to estimate the mean value of the season (spring max., summer season, autumn max.)
- Sometimes also areal composite samples are needed for more precise estimation (especially during blooming period in very eutrophic lakes)
- Mean value for the growing season and max. values are the determinands, which could be used in classification

In transportation of chlorophyll samples and in analyses of chlorophyll content in laboratory following practical guidance would be followed:

- Samples should be transported to the laboratory in cool boxes and sheltered from light
- If possible, the analysis should be started during the same day
- However, the samples can be preserved in the refrigerator over the night

- The chlorophyll *a* can be extracted by methanol, ethanol or acetone [in Finland the standard SFS 5772 (1993) uses ethanol (90%)]

## References

- Heinonen, P. & Herve, S. 1987. Water quality classification of inland waters in Finland. *Aqua Fennica* 17, 2: 147-156.
- Heinonen, P., Herve, S., Pietiläinen, O.-P., Puupponen, S., Sandman, O., Viljanen, M., Noges, T., Pannonhalmi, M., Rodrigues, R., Soszka, H & Sults, Y., 2003. Guidelines on Monitoring and Assessment of Transboundary and International Lakes. Part B: Technical guidelines. UN/ECE Working Group on Monitoring and Assessment. Finnish Environment Institute, Helsinki. 99 p. ISBN 952-11-1498-3, ISBN 952-11-1499-1(PDF).
- Lepistö, L. 1999. Phytoplankton assemblages reflecting the ecological status of lakes in Finland. *Monographs of the Boreal Environment research* 16, 43.

# Macrophytes as a tool to assess the ecological status of lakes

Jarkko Leka  
South-Savo Regional Environment Centre  
Jääkärintie 14  
50100 MIKKELI  
email: jarkko.leka@ymparisto.fi

## Introduction

Aquatic vegetation has been studied and classified in Finland quite actively since the 1930's (e.g. Cedercreutz 1934, Renkonen 1935, Metso 1936, Vaarama 1938, Maristo 1941), but there has not been a systematic monitoring programme using aquatic macrophytes. On the other hand there has not been standard for the surveying of macrophytes in lakes (CEN standard is under development) and therefore the comparisons of different data from various studies is difficult. A strong need for reliable methods for aquatic macrophyte monitoring arose by the implementation of the EU Water Framework Directive (WFD).

In the year 2000 South-Savo Regional Environment Centre began a macrophyte project, which studied field survey methods in lakes (Virola 2001). In 2001 macrophyte project continued as a part of the Life Vuoksi Project (2001-2004), with an aim to plan a cost effective, integrated pilot monitoring system, meeting the requirements of the WFD, for the Vuoksi River Basin. Evaluation of the usefulness of the monitoring methods for aquatic macrophytes, macrozoobenthos, periphyton and phytoplankton was one of the key objectives of the project (Leka *et al.* 2003, Tolonen *et al.* 2003, Sojakka *et al.* 2003). The tested macrophyte field survey methods were evaluated with regard to their cost-effectiveness and to their ability to provide quantitative and repeatable results and thus to detect changes in the abundance and structure of aquatic macrophyte vegetation.

In 2003 North-Savo and South-Savo Regional Environment Centers continued the macrophyte studies on the basis of results in the Life Vuoksi Project. The aim of the study was to assess different metrics describing the macrophyte community of lakes and to evaluate the use of the different metrics in the assessment of the ecological quality of small boreal lakes (Vallinkoski *et al.* 2004). The macrophyte data for the study was collected with aerial photograph interpretation and field surveys.

## Results of the macrophyte studies in the Life Vuoksi Project

### Field surveys

The reason for the study of field survey methods was that different survey methods had not been compared to each other and source of errors of methods had not been investigated. In 2001 several field study methods were tested: quadrat transects (quadrates 0,25 m<sup>2</sup> and 1 m<sup>2</sup>), belt transects (width 5 m and 10 m) and areal surveys (Figure 1). More species were found from the belt transects than from the adjacent quadrat transects and belt transects were quicker to study. Areal survey method was noticed be easy and quick method to collect species list with rough abundance estimates. Weaknesses of areal survey method was the lack of exact georeferenced data and the lack of ecologically important data (zonation of macrophytes, growing depths of macrophytes). Belt transect method in which vegetation is analysed on a 5 metre wide transect perpendicular to the shoreline was considered the most suitable.

It was concluded that the main belt transect method produces spatially quite accurate data of the taxonomic composition and relative abundances of aquatic macrophytes. Therefore it is suitable for the monitoring of temporal changes in aquatic macrophyte communities (Leka and Kanninen 2003).

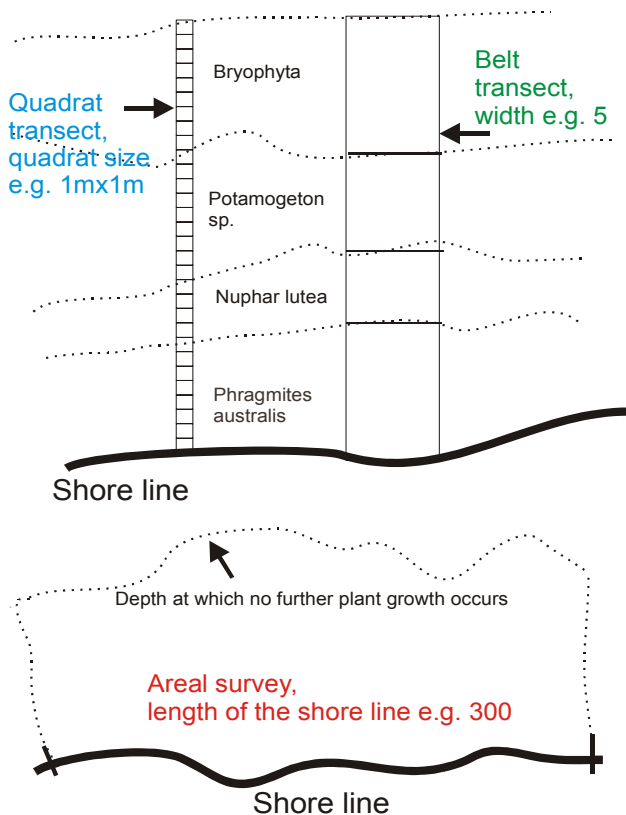

Figure 1. Schematic illustration of three field study methods.

Personal differences between observers in estimating the coverage and frequency of plant species were studied in order to be able to take these into account when planning monitoring schemes and interpreting results. Frequency and coverage estimates in belt transects made by different persons revealed that big differences (30-60%) between estimates were rare (< 5 % of cases). In one third of all frequency estimates the difference between persons was zero.

In lake Syysjärvi (1.7 km<sup>2</sup>) 52 transects at intervals ca 300 m were studied to find out the minimum number of transects needed per lake to obtain a reliable estimate of the species composition. In lake Syysjärvi, altogether 41 species of aquatic macrophytes (incl. vasculars, bryids and Characeae as one taxon) were found. On average, 90% of the total number of species was reached by studying 30 transects, 80% by studying 17 transects (Figure 2). Seven rare species, present at only one transect, were found.

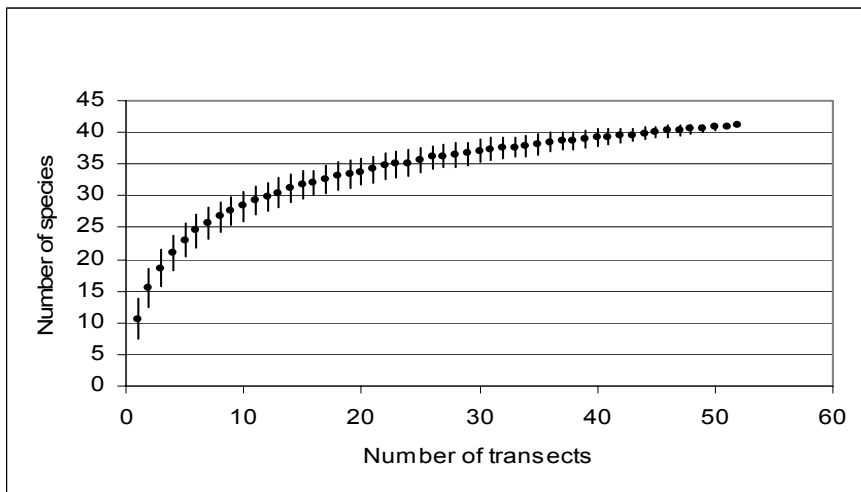

Figure 2. Rarefaction curve of the lake Syysjärvi macrophyte species. Points indicate the average number of species detected with a given number of transects, error bars indicate standard deviations.

## Aerial photograph interpretation

In the Life Vuoksi project it was tested two aerial photograph interpretation methods: numerical and visual interpretation. Numerical is based on the alternating reflectance of visual light from different kind of vegetation types. In the visual interpretation vegetation areas are identified by eyes from the aerial photographs. Aerial photograph interpretation can be used to produce vegetation maps to study spatial and temporal variations of aquatic vegetation. Accuracy of classification for both methods was about 80 %.

Digital colour infrared (CIR) aerial photographs representing 16 lakes of varying trophic status in the Vuoksi drainage basin, Finland, were used here to study the usefulness of remote sensing as a method for monitoring aquatic vegetation. The accuracy of the photo-interpretation method was assessed, and its ability to detect differences in the abundance of aquatic vegetation in lakes of varying trophic status was studied. Two measures of vegetation abundance based on the interpretation of aerial photographs, a colonization degree and a relative long-term change in the area of helophytes and nymphaeids, were used. The results indicated that CIR aerial photographs were suitable for mapping helophytic and nymphaeid vegetation and that the colonization degree of helophytes and nymphaeids was consistent with the nutrient content (total phosphorus and total nitrogen) of the lakes as well as with a measure of abundance based on field data (Valta-Hulkkonen *et al.* 2005).

Testing of the visual interpretation of the aerial photographs was focused on the helophytic and nymphaeid vegetation, and the classification was mainly performed to species level (Leka *et al.* 2003). Aerial photograph interpretation of aquatic vegetation reveals changes in abundance of life-forms indicative of human impact and may be a usable, cost-effective tool to measure the abundance of aquatic vegetation.

## Metrics to assess the ecological status

According to the results of studies in small (area < 5 km<sup>2</sup>) boreal lakes (slightly, moderately and very humic lake types) we concluded that most suitable macrophyte metrics to assess the ecological status of lakes are number of species, percentage of type specific species and percentage of potential colonization area vegetated (Figure 3, Vallinkoski *et al.* 2004). Percentage of potential colonization area vegetated was measured with numerical photograph interpretation. This index correlated well

with the current trophic status of the lakes. Percentage of potential colonization area vegetated was higher in impacted lakes. In the moderately humic lake type, the vegetation visible from aerial photographs was increased in loaded lakes in comparison to the reference lakes, while in the very humic lakes, the difference in abundance was less evident (Figure 3). The abundance measure based on the aerial photograph interpretation was in good agreement with the field survey results (Kanninen *et al.* 2003).

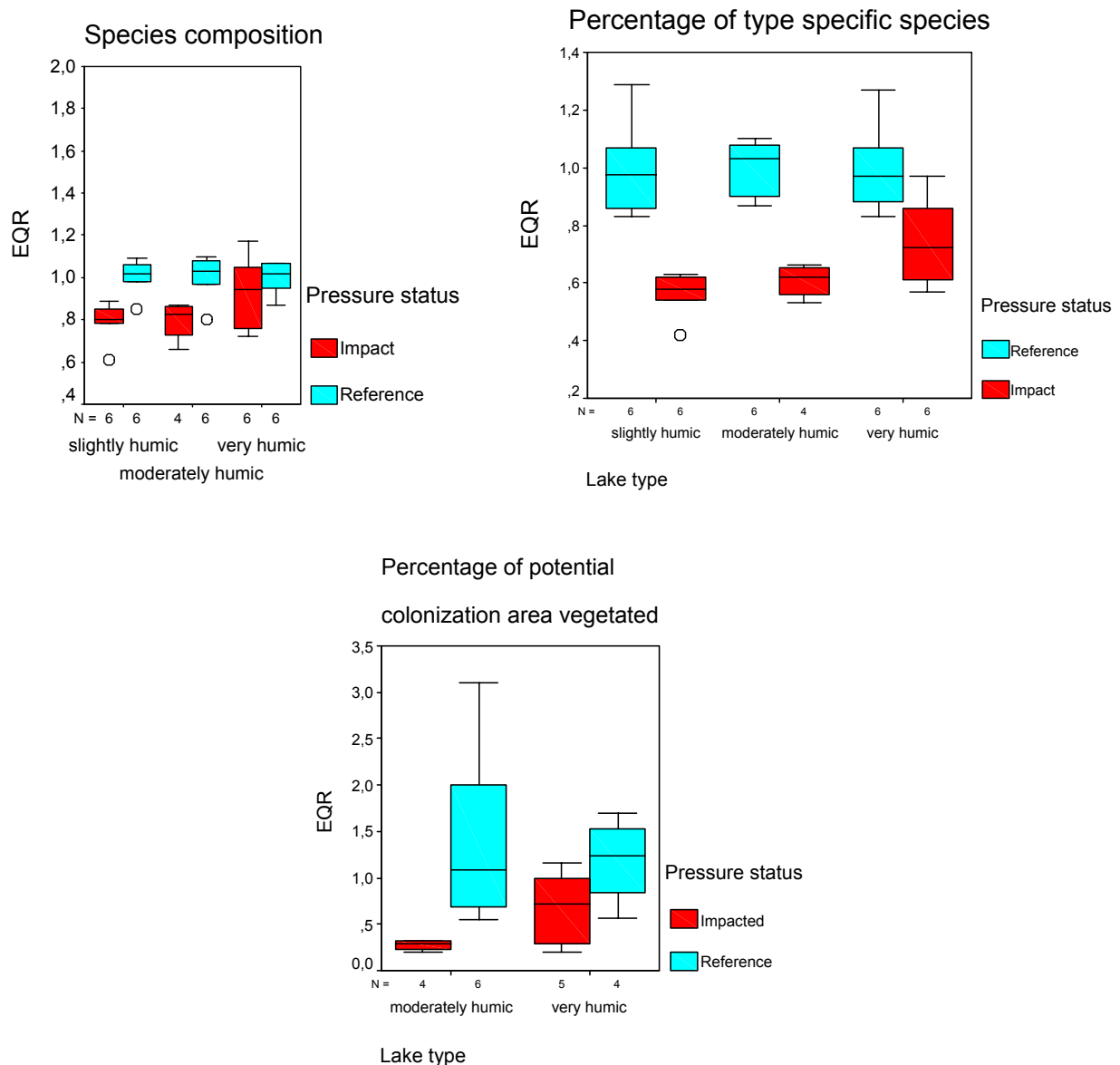

Figure 3. Ecological Quality Ratios of reference and impacted lakes on three boreal lake types calculated by species composition, percentage of type specific species and percentage of potential colonization area vegetated.

## References

- Cedercreutz, C. 1934: Die Algenflora und Algenvegetation auf Åland. Acta Bot. Fennica 15: 1-120.
- Kanninen, A., Leka, J., Vallinkoski, V.-M. and Ilvonen, R. 2003: Aerial photograph interpretation and field surveys of aquatic macrophytes in the assessment of ecological status of small boreal lakes - preliminary results. In: How to assess and monitor ecological quality in freshwaters. Marja Ruoppa, Pertti Heinonen, Ansa Pilke, Seppo Rekolainen, Heikki Toivonen and Heidi Vuoristo (eds.) - Copenhagen : Nordic Council of Ministers 2003.

- Leka, J. and Kanninen, A. 2003: Field surveys of aquatic macrophytes as a tool for monitoring and assessing the ecological status of the boreal lakes. In: How to assess and monitor ecological quality in freshwaters. Marja Ruoppa, Pertti Heinonen, Ansa Pilke, Seppo Rekolainen, Heikki Toivonen and Heidi Vuoristo (eds.) - Copenhagen : Nordic Council of Ministers 2003.
- Leka, J., Valta-Hulkkonen, K., Kanninen, A., Partanen, S., Hellsten, S., Ustinov, A., Ilvonen R. ja Airaksinen O. 2003. Vesimakrofytyt järvien ekologisen tilan arvioinnissa ja seurannassa : maastomenetelmien ja ilmakuvatulkinnan käyttökelpoisuuden arviointi Life Vuoksi -projektissa. Alueelliset ympäristöjulkaisut 312. Etelä-Savon ympäristökeskus ja Pohjois-Savon ympäristökeskus. 96 s.
- Maristo, L., 1941. Die Seetypen Finnlands auf floristischer und vegetationsphysiognomischer Grundlage. Ann. Bot. Soc. Zool.-Bot. Fenn. Vanamo 15(5): 1-312.
- Metso, V. 1936: Kasvistosta ja kasvillisuudesta eräissä Konneveden pikku järvissä. Ann. Bot. Soc. Vanamo 8 (2): 1-39.
- Renkonen, O. 1935: Über das Verhalten der Wasserpflanzen zur Reaktion in einigen Gewässern Mittelfinnlands. Ann. Univ. Turku. A IV 2: 1-44 + kartta.
- Sojakka, P., Manninen, P. & Airaksinen, O. 2004. Päälyllyskasvustot ja kasviplankton järvien ekologisen tilan arvioinnissa ja seurannassa: Menetelmien käyttökelpoisuuden arviointi Life Vuoksi -projektissa. Alueelliset ympäristöjulkaisut 333. Etelä-Savon ympäristökeskus ja Pohjois-Savon ympäristökeskus. 101 s.
- Tolonen, K., Hämäläinen, H., Luotonen, H. & Kotanen, J. 2003. Rantavyöhykkeen pohjaeläimet järvien ekologisen tilanarvioinnissa ja seurannassa : Menetelmien käyttökelpoisuuden ja kustannustehokkuuden arviointi Life Vuoksi -projektissa. Alueelliset ympäristöjulkaisut 328. Pohjois-Karjalan ympäristökeskus. 60 s.
- Vaarama, A. 1938: Wasservegetationsstudien am Grosse Kallavesi. Ann. Bot. Soc. Zool.-Bot. Fenn. Vanamo 16(Suppl.): 33-49.
- Vallinkoski, V.-M., Kanninen, A., Leka, J. ja Ilvonen, R. 2004: Vesikasvillisuus pienten järvien tilan ilmentäjänä. Ilmakuvatulkintaan ja maastoseurantaan perustuvat ekologisen tilan mittarit. Suomen ympäristö 725. 90 s.
- Valta-Hulkkonen, K., Kanninen, A., Ilvonen, R. & Leka, J. 2005: Assessment of aerial photography as a method for monitoring aquatic vegetation in lakes of varying trophic status. Boreal Env. Res. 10: 57–66.
- Virola T. 2001: Vesimakrofytytseurantojen kehittäminen Saimaan alueella. Väkiraportti, kesä 2000. Etelä-Savon ympäristökeskuksen moniste 28. 28s ja karttaliite a-f.

# Macrophytes – a tool to classify the ecological status of lakes. Estonian experience

Helle Mäemets  
Institute of Agriculture and Environmental Sciences  
Estonian Agricultural University  
61101 Centre of Limnology  
Rannu, Tartu County  
Estonia  
helle@zbi.ee

## Historical background

The earliest descriptions of the macrophyte vegetation of some Estonian lakes date from the beginning of the 20<sup>th</sup> century (Oettingen, 1906; Mühlen, M., 1908 a, b; 1911 a, b; Mühlen, L., 1910; Mühlen & Schneider, 1920). In the 1920s and 1930s, complex investigations of 76 small lakes in Eastern Estonia, provided also brief data about macrophytes (Riikoja, 1940). Botanists published several special descriptions of the vegetation: Lippmaa (1928), Sirgo (1935), Pastak (1936), Eichwald (1939), Miljan (1958); the data by P. Kaaret remained in the manuscript form. Valuable data about macrophytes were also contained in the works of other naturalists (Bekker & Audova, 1923; Haberman, 1937; Zelnin, 1941; Ristkok & Ruse, 1962).

An extensive inventory of Estonian lakes with a surface area more than 10 ha was started in the 1950s. As a result, the data by H. Tuvikene and her colleagues about the macrovegetation of 150 lakes were published in the book “Eesti järved” (Estonian Lakes) in 1968. This book includes also the vegetation maps of 94 lakes. The data of the proportion of the lake’s area covered by macrophyte stands was mostly based on bathymetric maps. Five classes of coverage estimation were used: < 10% - very low; 10-24% - low; 25-49% - moderate; 50-74% - high; 75-100% - very high. The plant associations of oligotrophic and eutrophic lakes were described by L. Laasimer (1965). The first overview of the macroflora of L. Peipsi was published in 1966 (H. Tuvikene) and that of L. Võrtsjärv in 1973 (A. Mäemets).

New investigations of small lakes were launched in the 1960s by Aime Mäemets, a researcher of the Võrtsjärv Limnological Station (Mäemets, 1965, 1982, 1991a, 1991b, 1991c). In that period, also many lakes with a surface area less than 10 ha were studied during complex expeditions (hydrochemistry, macrophytes, phytoplankton, zooplankton, zoobenthos and fishes). Part of these results were published in an overview by Aare Mäemets (1977) and were presented in numerous contract reports (manuscripts preserved at the Võrtsjärv Limnological Station).

## Actual state of monitoring data

Today, the database of the Võrtsjärv Limnological Station includes most older data (mentioned above) and the data collected by botanists of the Station in the period 1965-2004. The database covers about 500 lakes. One third of the lakes have been monitored three or more times, another third twice and still another third once. There are data about depth limit, percentage of the lake’s area covered by vegetation (not for all lakes) and abundance of taxa on the Braun-Blanquet scale. When abundance is not estimated, it is marked as -999 (for statistical analysis). In most cases abundance is not estimated for hygrophytes in the lakes with a wide and thick belt of emergent plants. At every monitoring, the older data has been compared with the latest ones.

The lists of taxa and their frequency estimates for L. Peipsi and L. Võrtsjärv have been published in articles and monographs (Mäemets & Mäemets, 2000; Mäemets & Mäemets, 2001; Mäemets, 2002; Feldmann & Mäemets 2003; Feldmann & Mäemets, 2004). The percentages of the hydrophyte (submerged, floating and floating-leaved plants) stands for lake's area, including also the species number of the main groups, were entered in a special database (206 lakes) by Aime Mäemets, including also species number of main groups. The estimates on the point scale (1-5) are analogous to those given in "Estonian Lakes": <10% - 1; *etc.* This database has served as a basis for the generalized characterization of the macrophyte associations and their quantitative characteristics in the lake typology of Estonian lakes developed for the EU Water Framework Directive by I. Ott .

## Classification for Water Framework Directive

The estimates of PVI (Plant Volume Infested) have been recently available only for several lakes, but they should be used in monitoring in the future. The author's opinion is that it is important to continue monitoring also in the traditional way with the aim to make comparison with older data. The EU methods should be integrated with the earlier method. By taking into account only the main plant groups or confirmed indicative species, the continuity and completeness of floristic data for lakes will be lost. Not only the hydrophytes but also the emergent plants should be placed in the focus of research.

Use of Estonian experience in macrophyte investigation for lakes of other countries, *e.g.* Finland, is restricted owing to different environmental conditions and the corresponding floristic composition. The limestone bedrock of large areas and the lime-rich till of our elevations on Devonian sandstone explains the domination of hard-water, naturally eutrophic lakes in Estonia. Another large group – dystrophic and acidotrophic lakes – have mostly a too scarce vegetation to serve as a classification tool. Considering natural differences, we will deal with several issues related to the classification in question.

It is very difficult to decide what type of vegetation should be considered an example for reference conditions. One reason is the mentioned regional specificity, which depends on the geological background, climate and history (*e.g.* preceding flax retting period). For example, regarding data from Sweden, Germany and North-Kazakhstan, the total phosphorus content of water for the successful growth of charophytes does not exceed  $0.002 \text{ mg l}^{-1}$  (Forsberg, 1965; Krause, 1981; Sviridenko, 2000). This critical level is generally valid also for Estonia. However, according to Berg (1999), charophytes disappeared from Veluwemeer in the Netherlands at  $P_{\text{tot}} 0.3 \text{ mg l}^{-1}$  and recolonized the lake at  $0.1 \text{ mg l}^{-1}$ .

Another reason is the individuality of lakes. For example, the transition charophytes → *Potamogeton* spp. → *Myriophyllum* sp. - *Potamogeton* spp. (Kowalczewski & Ozimek, 1993) has taken place in the course of the eutrophication of many hard-water lakes of Estonia. However, in some lakes *Myriophyllum* does not grow at all. Very common species (*Phragmites australis*, *Nuphar lutea*, *Potamogeton natans*) are absent from some "ordinary" lakes.

Despite the abundant presence of characteristic species, the Estonian oligotrophic lakes display some signs of changing trophic level, which have not received sufficient attention by investigators. The following signs could be mentioned:

- 1) thick cover of epiphytic algae (see also Sand-Jensen & Søndergaard, 1997);
- 2) decreasing moss bed; dead moss polster which hinders recolonization;
- 3) hybrids between characteristic species of the type and widespread common species (genera *Sparganium*, *Nuphar*);

- 4) appearance of elodeid species;
- 5) invasion of taller emergent plants.

Soft-water oligotrophic lakes cannot be given a “high” or “reference” status if any of these signs are presented.

A thick microepiphyton and large filamentous algae are also characteristic of nitrogen-rich hard-water lakes. Yet use of these groups as an indicator is to some degree complicated due to large inter-annual differences, probably largely caused by weather conditions (Laugaste *et al.*, 2003; Mäemets & Freiberg, unpublished data). In case these species occur in large amounts, the estimate for the lake must be near the limit of “good/moderate”, or lower.

In shallow hard-water lakes the high coverage of submerged plants, especially charophytes, is considered as the sign of a good or high state (Scheffer, 1998; Berg, 1999 *etc.*). However, when this criterion is used, the areas under strong mechanical stress (e.g. eastern coasts of the lakes Peipsi and Võrtsjärv) and very shallow lakes on the bedrock (some Estonian coastal lakes) should be excluded.

The reeds are expanding owing to nutrient loading, low-water periods (or crustal uplift) and the decline of pasturing. At transition from the “high” state of the mesotrophic northern part of L. Peipsi to a “good” or “moderate” state, increase in reeds has been the most obvious change (Mäemets & Freiberg, 2004). In the open water, *Potamogeton perfoliatus* has dominated through the last 40 years. The shelter of reeds favours accumulation of organic sediments and appearance of shadow-tolerating nutrient-demanding species (*Ceratophyllum demersum*, *Spirodela polyrhiza*). Thus in open water and among reed stands there occur different vegetation types corresponding to different classification estimates.

In the eutrophication of small calcareous lakes the dominance of floating-leaved plants with weakly anchored ceratophyllids and lemniids is the following step to the transition: charophytes → elodeids (*Elodea* – *Potamogeton* – *Myriophyllum*) and should be estimated as “moderate” or worse. Usually, at this stage shallow lakes are largely overgrowing with tall emergent plants. The author supposes, that during the first steps of the described transition changes are caused by nutrient inflow, while further on change in bottom sediments may play a more important role in macrophyte composition.

The water of stratified *Ceratophyllum* –lakes is usually in the summer period transparent and the epilimnion may be poor in nutrients. The dominance of this species may indicate accumulation of loose organic-rich sediment over the years of nutrient loading, but not actual loading (Mäemets & Freiberg, in print).

Macrophytes are considered valuable indicators on account of their “long memory”. This opinion is more justified regarding the composition of the macrophyte vegetation, however, less frequent species for a particular lake may be absent in some years. The abundance of the (especially submerged) vegetation has a shorter “memory” and is quite variable in different years. Heavy rains, as was the case in 2004, may cause an inflow of large amounts of organic matter, while charophytes or other submerged plants decline in brownish water. The situation in the following summer will be obviously influenced by these circumstances. Although a single visit enables to more or less exactly determine the type of the lake, however, the classification estimate may be not right.

Despite all difficulties as described in part above, revision of the quality of lakes would a useful activity in the aspects of their future as well as nature protection.

## Acknowledgements

I am grateful to H. Tuvikene and to the late Aime Mäemets who have collected the overwhelming majority of the macrophyte data. I am much obliged to R. Laugaste and T. Trei for their help and support, as well to L. Freiberg, creating an electronic database, and to K. Palmik for help in monitoring in 2004. The English was revised by E. Jaigma. Our investigations are supported by the co-grants of Estonian Ministry of Education and Research No. 0362482s03, 0362483s03, 0370208s98, and by the Estonian Science Foundation grants No. 3579, 4835 and 4986.

## References

- Bekker, H. & A. Audova, 1923. Andmeid Pühajärve uurimisest. "Odamees", 80 lk.
- Berg, M. S. van den, 1999. Charophyte colonization in shallow lakes. Theses Vrije Universitet Amsterdam, 137 pp.
- Eesti järved (Estonian Lakes), 1968. Ed. by Aare Mäemets, "Valgus", Tallinn, 548 pp.
- Eichwald, K., 1939. Võrtsjärve taimestik. In: Viljandimaa I. Eesti Kirjameeste Seltsi Kirjastus, Tartu: 57-59.
- Feldmann, T. & Mäemets, H. 2003. Suurtaimed. In: Haberman, J., Pihu, E. & Raukas, A. (eds.), Võrtsjärv. Eesti Entsüklopeediakirjastus, Tallinn, 225-247.
- Feldmann, T & H. Mäemets, 2004. Macrophytes. In: Haberman, J., Pihu, E. & Raukas, A. (eds.), Lake Võrtsjärv. Estonian Encyclopaedia Publishers, Tallinn, 185-205.
- Forsberg, C., 1965. Environmental conditions of Swedish Carophytes. Symb. Bot. Upsal. 18 (4), 3-67.
- Haberman, H., 1937. Der See Kälajärv als Beispiel einer eu-dys Sukzession. Symbolae ad Estoniae Lacus Explorandos, 21.
- Kowalczewski, A. & T. Ozimek, 1993. Further long-term changes in submerged macrophyte vegetation of the eutrophic Lake Mikolajskie (North Poland). Aquat. Bot. 46: 341-345.
- Krause, W., 1981. Characeen als Bioindikatoren für den Gewässerzustand. Limnologica 13 (2), 399-418.
- Laasimer, L. 1965. Eesti NSV taimkate. Tallinn, 396 lk.
- Laugaste, R., Mäemets, H., Reunanen, M. & L. Freiberg, 2003. Characteristics of epiphyton and its connections with macrovegetation in ten small Estonian lakes of different type. – Lake ecosystems: biological processes, anthropogenic transformation, water quality. Mat. 2<sup>th</sup> Int. Sc. Conf. Minsk-Naroch, Sept. 22-26, 383-387.
- Miljan, A. 1958. Toitainetevaeste järvede vegetatsioonist Eesti NSV-s. TRÜ Toimetised, 64, Botaanika-alased tööd, 1, 119-137.
- Mäemets, Aare, 1977. Eesti NSV järved ja nende kaitse. Tallinn, "Valgus", 263 lk.
- Mäemets, Aime, 1965. Andmeid mõnede Kagu-Eesti väikeste järvede makrofloorast. Loodusuurijate Seltsi Aastaraamat 57, 31-50.
- Mäemets, Aime, 1973. Kõrgem taimestik. In Timm, T. (ed.), Võrtsjärv. Valgus, Tallinn: 77–82; 205–206.
- Mäemets, Aime, 1982. Antropogeense eutrofeerumise mõju eri tüüpi järvede suurtaimestikule (makrofloorale). In: Simm, H. (ed) Eesti NSV järvede nüüdisseisund. Tartu, 116-124.
- Mäemets, Aime, 1991a. Suurtaimestik. In H. Timm (ed.), State of Lake Verevi (Hydrobiological Researches XVII), Tartu: 95-106.
- Mäemets, Aime, 1991 b. Makrofüta. In Timm, T. (ed.), State of the Estonian soft-water lakes, Tartu, 80-122 (Macrophytes. In Russian).
- Mäemets, Aime, 1991c. Suurtaimestik kui järvede hindamise informatsiooniallikas. In Saarse, L. (ed.), Inimene ja geograafiline keskkond. Vabariikliku geograafia-alase nõupidamise materjalid. Tallinn, 93-97.

- Mäemets, H. & Mäemets, Aime†, 2000. Commented list of macrophyte taxa of Lake Peipsi. Proc. Estonian Acad. Sci. Biol. Ecol. 49, 1,136-154.
- Mäemets, A.† & Mäemets, H. 2001. Macrophytes. In: Haberman, J. & Pihu, E. (eds.). Lake Peipsi. III. Flora and Fauna, 9-22.
- Mäemets, H., 2002. Commented list of macrophyte taxa of Lake Võrtsjärv. Proc. Estonian Acad. Sci. Biol. Ecol. 51 (1): 5-25.
- Mäemets, H. & L. Freiberg. Characteristics of reeds on Lake Peipsi and the floristic consequences of their expansion. Limnologica 34, 83-89.
- Mäemets, H. & L. Freiberg. Long- and short-term changes of the macrophyte vegetation in strongly stratified hypertrophic Lake Verevi. Hydrobiologia (in print).
- Mühlen, L. zur, 1910. Der Soiz-See, seine Entstehung und heutige Ausbildung. Sitzungsber. Naturf. - Ges. Univ. Jurjew (Dorpat), 18, (2-3).
- Mühlen, M. zur, 1908a. Die Raugeschen Seen. Sitzungsber. Naturf. - Ges. Univ. Jurjew (Dorpat), 17 (3-4).
- Mühlen, M. zur, 1908b. Mitteilungen über die Seen von Tilsit, Alt-Waimel und Schreibershof. Sitzungsber. Naturf. - Ges. Univ. Jurjew (Dorpat), 17 (3-4).
- Mühlen, M. zur, 1911a. Der Saadjärw-See. Sitzungsber. Naturf. - Ges. Univ. Jurjew (Dorpat), 19 (3-4).
- Mühlen, M. zur, 1911b. Der See von Kehrimois Uhlfeld. Sitzungsber. Naturf. - Ges. Univ. Jurjew (Dorpat), 19 (3-4).
- Mühlen, M. zur & Schneider, G. 1920. Der See Wirzjerw in Livland. Archiv für die Naturkunde des Ostbaltikums, 14, 1.
- Oettingen, H., 1906. Vorläufiger Bericht über botanischen Ergebnisse der Seeforschung im Sommer 1905. Materialien zur Erforschung der Seen Livlands.
- Pastak, E., 1936. Võrtsjärve idaranniku taimkattest. Eesti Loodus 4: 137-140.
- Riikoja, H., 1940. Zur Kenntnis einiger Seen Ost-Eestis, insbesondere ihrer Wasserchemie. Annales Societatis rebus naturae investigandis in Universitate Tartuensi constitutae, 46:168-329.
- Ristkok, J. & K. Ruse, 1962. Võrtsjärve litoraali põhjafauna koosseisust ja levikust. TRÜ Toim. 120. Zooloogia-alaseid töid: 3-52.
- Lippmaa, T., 1928. Taimestik. In: Setumaa, EKS Kirjastus, Tartu, 28-31, 180-193, 247-254, 294-297.
- Sand-Jensen, K. & M. Søndergaard, 1997. Plants and environmental conditions in Danish *Lobelia*-lakes. In Sand-Jensen, K. & Pedersen, O. (eds.), Freshwater Biology. Priorities and Development in Danish Research. On the one hundredth anniversary of the Danish Freshwater Biological Laboratory. G.E.C. Gad, Copenhagen, 54-72.
- Scheffer, M., 1998. Ecology of shallow lakes. Chapman & Hall, 345 pp.
- Sirgo, V. 1935. Emajõe alamjooksul Peipsiäärsel madalikul asuvaist taimetüingust. - Tartu Ülikooli ja LUS-i aruanded, XLII, 114-176.
- Sviridenko, B.F., 2000. Flora i rastitel'nost' vodoemov Severnogo Kazakhstana Omsk, 196 pp. (in Russian).
- Tuvikene, H. 1966. O vysšej vodnoi rastitel'nosti Chudsko-Pskovskogo ozera. Hydrobiological Researches 4, Tallinn, 75-79 (in Russian).
- Zelnin, V. 1941. Ornitoloogilisi vaatlusi Peipsi läänerannikult 1938. a. suvel. - Eesti Loodus (*Miscellaneous II* - Tartu Ülikooli Zooloogia Instituudi ja Muuseumi tööd), 27, 70-74.

# Mussels in estimation of organic compounds and heavy metals in classification of the chemical status of surface waters

Sirpa Herve  
Central Finland Regional Environment Centre  
P.O.Box 110  
40101 Jyväskylä  
Finland  
sirpa.herve@ymparisto.fi

## Introduction

Water Framework Directive (WFD) requires, that both ecological status and chemical status should be determined for River Basin Management Plan. Chemical status should be determined using the data of priority substances and other toxic or harmful compounds mentioned in Annex VIII and IX (especially the Dangerous Substance Discharges Directive). There are only two classes of chemical status: good or failing to achieve good.

The chemical status “good” means, that water body has achieved compliance with all the environmental quality standards established in Annex IX, Article 16 (Strategies against pollution of water), and under other relevant Community legislation setting environmental quality standards. The measurements of chemical pollutants is extremely important in classification work.

## Persistent Organic Pollutants (POPs)

One of the most well-known groups of chemicals, which may be significantly dangerous in the water courses are the persistent organic pollutants, called POPs or mentioned in some context as Dirty Dozen. The list of POPs is as follows:

- Aldrin/ A pesticide used to protect crops from soil insects. Widely banned.
- Chlordane/ A pesticide used to protect crops from termites. Widely banned.
- DDT/ A pesticide used on crops for vector control. Used on troops during the World War II to stop malaria, typhus and other diseases. Widely banned. Still produced and used.
- Dieldrin/A pesticide used for the control of insects and disease vectors. Restricted.
- Dioxins/ Industrial by-products. Limited regulation.
- Furans/Industrial by-products. Limited regulation.
- Endrin/ Pesticide used on field crops and to control rodents. Widely banned.
- Hexachlorobenzene (HCB)/ A pesticide and industrial by-product released during plastics manufacture. Its use as a pesticide is widely banned. Limited regulation of by-products.
- Heptachlor/ A pesticide used against soil insects and termites. Widely banned.
- Mirex/ A pesticide used against various ants, termites, wasps and bugs. Also used as a fire retardant in plastics, rubber, paint paper and electrical goods. Widely banned.
- Polychlorinated biphenyls (PCBs)/An industrial chemical used in heat exchange fluids, paint additives, carbonless copy paper, plastics and various other industrial applications. Released as a by-product. Widely banned. Limited regulation of releases.
- Toxaphene/ A pesticide used on cotton, grains, fruits, nuts and vegetables and to control ticks and mites in livestock. Widely banned.

## Other organic compounds

Besides POPs there are a great number of other organic compounds, which can be very problematic in rivers and lakes. A very famous group of these are the Priority substances mentioned in the WFD. The complete list (accepted in 2001) is as follows:

- 1) Alachlor
- 2) Anthracene
- 3) Atrazine
- 4) Benzene
- 5) Brominated diphenylethers
- 6) Cadmium and its compounds
- 7) C10-13-chloroalkanes
- 8) Chlorfenvinphos
- 9) Chlorpyrifos
- 10) 1,2-Dichloroethane
- 11) Dichloromethane
- 12) Di(2-ethylhexyl)phthalate (DEHP)
- 13) Diuron
- 14) Endosulfan; (alpha-endosulfan)
- 15) Fluoranthene
- 16) Hexachlorobenzene
- 17) Hexachlorobutadiene
- 18) Hexachlorocyclohexane; (gamma-isomer, Lindane)
- 19) Isoproturon
- 20) Lead and its compounds
- 21) Mercury and its compounds
- 22) Naphthalene
- 23) Nickel and its compounds
- 24) Nonylphenols; (4-(para)-nonylphenol)
- 25) Octylphenols; (para-tert-octylphenol)
- 26) Pentachlorobenzene
- 27) Pentachlorophenol
- 28) Polyaromatic hydrocarbons
  - ✓ (Benzo(a)pyrene),
  - ✓ (Benzo(b)fluoroanthene),
  - ✓ (Benzo(g,h,i)perylene),
  - ✓ (Benzo(k)fluoroanthene),
  - ✓ (Indeno(1,2,3-cd)pyrene)
- 29) Simazine
- 30) Tributyltin compounds; (Tributyltin-cation)
- 31) Trichlorobenzenes; (1,2,4-Trichlorobenzene)
- 32) Trichloromethane (Chloroform)
- 33) Trifluralin

## Heavy metals

Heavy metals are a group of heavy, dense, metallic elements that occur only at trace levels in water, but are very toxic and tend, as like the mercury, to accumulate in biota. The most important heavy metals, which should be monitored in water courses are:

- Antimony (Sb)
- Arsenic (As)
- Cadmium (Cd)

- Chromium (Cr)
- Lead (Pb)
- Mercury (Hg)
- Nickel (Ni)
- Zinc (Zn)

Usually the concentrations are at present very low, and also the trend is in most cases decreasing. The main anthropogenic sources of heavy metals are various industrial point sources (present or in many cases also historical, old landfills (municipal and industrial), non-point loading from different sources and airborne pollution (especially Hg in the Arctic areas).

## Different ways to monitor the harmful substances

There are five main ways to monitor harmful substances or compounds in different compartments of the environment:

- Water samples (if the concentrations are high enough for measuring)
- Continuous monitoring of different organic compounds in natural biota of some lakes, rivers and coastal areas
- Monitoring of harmful substances in fresh water recipient water courses with the so called mussel incubation method (bioaccumulation)
- Use of passive accumulation devices (Semipermeable membrane devices, SPMDs)
- Sediments.

## The mussel incubation method

The discharges of the industry contain a large number of organic compounds in so low concentrations that they cannot be found by chemical means. The concentrations of pollutants in non-point loading are also very low. Besides, the concentrations fluctuate in wide ranges especially in the recipient water bodies. The standardization of the method based on bioaccumulation (same animal, same incubation time, no contact with sediments) has improved the comparability. The principle of the mussel incubation method is presented in Figure 1.

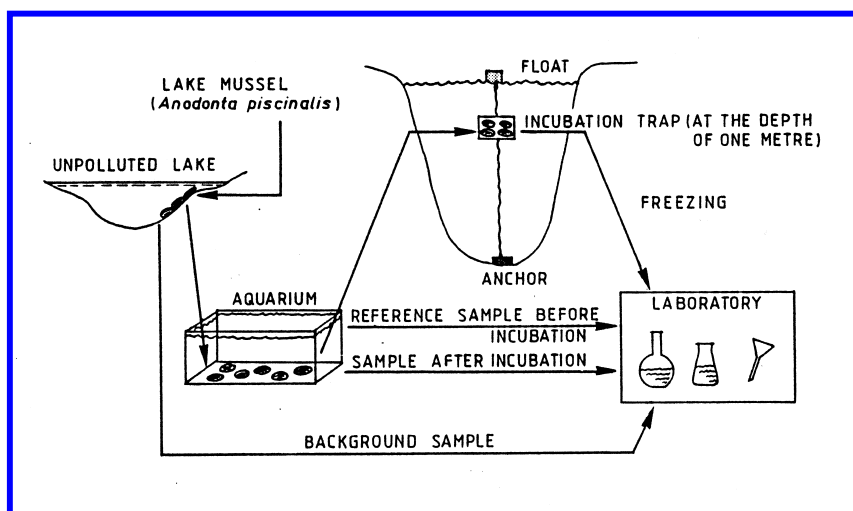

Figure 1. The principle of the mussel incubation method

Some results from cases, where mussel incubation method has been used successfully are presented in Figures 2 and 3.

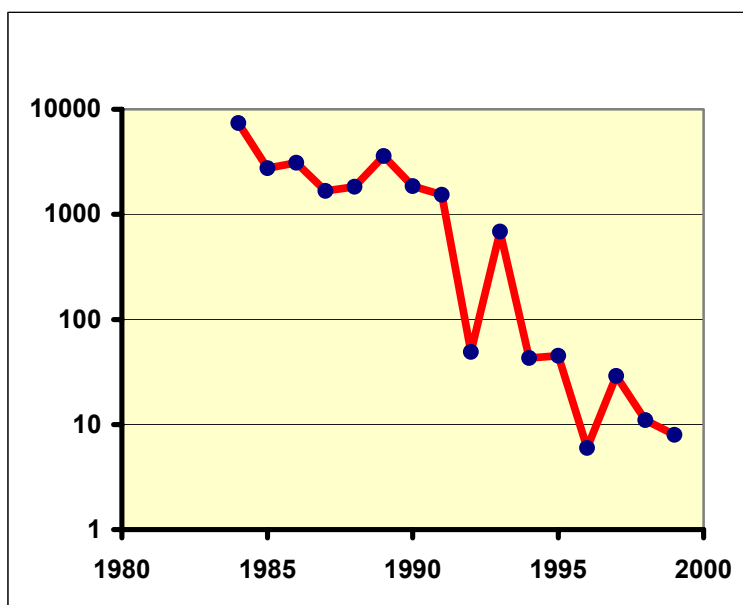

Figure 2. The concentration of organic chlorine compounds originating from pulp bleaching in mussels (ng/g, lw, log scale)

The decrease of using free chlorine in bleaching pulp, as well as the improved waste water treatment with biological methods has improved the situation generally in all the receiving water bodies of pulp and paper industry.

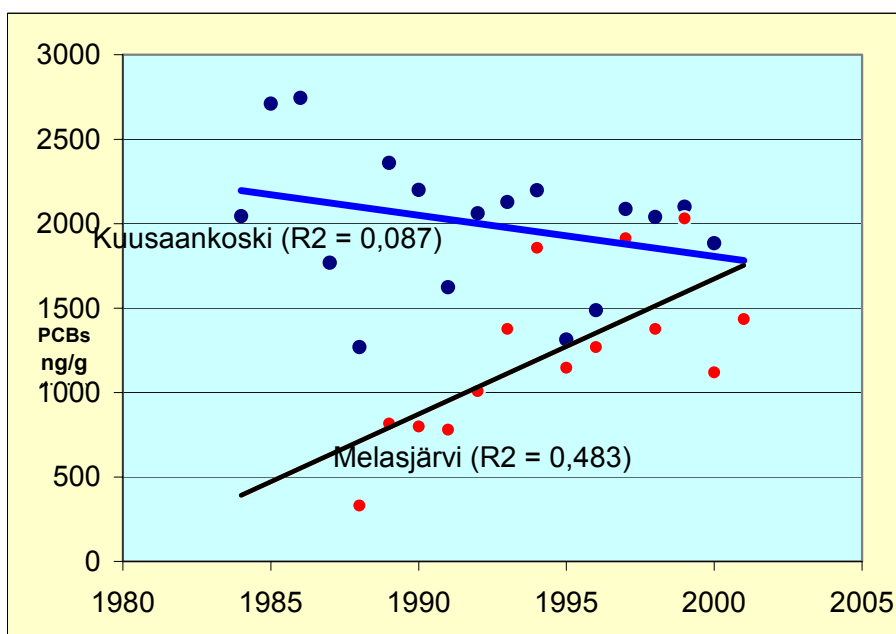

Figure 3. PCBs in two Finnish Lakes

The incubation site at Kuusaankoski is affected by an old industrial area, from which PCBs are washing out step by step. The other case is from Lake Melasjärvi, where the increase of PCBs in incubated mussels is possibly a consequence from using recycled paper in processes.

## References

Herve, S., Heinonen, P. & Paasivirta, J. 2002. Survey of organochlorines in Finnish watercourses by caged mussel method. *Resources, Conservation and Recycling*. Volume 35, 1-2 (April 2002) 105-115.

# Periphyton as a tool to classify ecological status of inland waters

Sirje Vilbaste  
Institute of Agricultural and Environmental Sciences  
Estonian Agricultural University  
Tartu  
sirje.vilbaste@zbi.ee

Diatoms have been extensively used in water quality monitoring for a long time. Round (1991) has presented a history of diatom research, related to river water quality, starting with a study by Kolkwitz and Marsson (1908). In the last decade, five relevant symposia took place: Düsseldorf 1991 (Whitton *et al.* 1991), Innsbruck 1995 (Whitton & Rott 1996), Douais 1997 (Prygiel *et al.* 1999), Durham 2000, and Krakow 2003. A number of workshops have also been dedicated to this topic.

In several European countries, different diatom indices have been widely used for the monitoring of running waters: Trophic Diatom Index (TDI) in Great Britain (Kelly 1998), Descy & Coste Diatom Index (CEC), Descy's index, Generic Diatom Index (GDI), and Specific Pollution Sensitivity Index (SPI) in France (Prygiel & Coste 1996), CEC and SPI in Belgium and Luxembourg (Descy & Ector 1999). The limit values for GDI, SPI, and TDI have been established for Finnish rivers (Eloranta & Soininen 2002).

Diatoms are appropriate organisms for use in monitoring:

- diatom communities are very rich in species and have an almost ubiquitous occurrence;
- the life cycle of diatoms is short and the communities respond quickly to changes in water quality;
- it is easy to collect and store them, each sample on a permanent slide;
- the taxonomy of diatoms is well developed and the manuals are available, however, skills for determination of species are indispensable.

In the European Union a standard for routine sampling and pretreatment of benthic diatoms from rivers has been worked out (CEN 230 2002) in order to use them in the monitoring of running waters. Another standard for identification, enumeration and interpretation of benthic diatom samples from running waters is in preparation (preEN 14407). The software OMNIDIA (Lecoite *et al.* 1993), which helps calculate different diatom indices according to the composition and structure of diatom assemblages, was developed in France.

It has been demonstrated previously that water quality in Estonian streams is reflected only by the epilithic diatom community and not by the epipelic community or the epiphytic community (Vilbaste 2001). The fact that the epilithic diatom community suits best for river monitoring has also been stressed by the diatomists Cox (1991) and Round (1991) from the United Kingdom.

Microphytobenthic primary producers use dissolved nutrients directly from water. The composition and structure of periphytic diatom assemblages is formed as a consequence of biological response to water quality over time. An occasional water analysis can give only a rough estimation of average nutrient level and therefore the environmental factors measured simultaneously with sampling of diatoms do not often correlate well with the diatom indices (Table 1). Round (1991) too emphasized low correlation between the biological indices and the chemical parameters of the water.

Not all of the 16 calculated indices are suitable for assessment of water quality in Estonia. The diversity indices, like Shannon-Weaver diversity index ( $H'$ ), Evenness index ( $I$ ), and number of taxa ( $Tax$ ), are not appropriate serving as environmental indicators. They tend to have the highest values for intermediate conditions (Fig. 1). Archibald (1972), Lobo *et al.* (1995), and Jüttner *et al.* (1996) have also stressed that measurement of the species diversity of algae is not a proper method for water quality assessment.

Although the fluctuation range for the values of Generic Diatom Index (GDI) was among the largest, its median values revealed no significant differences when used either on the scale of water trophicity or according to the quality classes. The same applied also to Artois-Picardie Diatom Index (IDAP). Hence, these two indices are not fit for water quality assessment in Estonia. Nor are Rott's index and Diatom-based Eutrophication / Pollution Index (Epid-D) suitable for estimation of the state of a water body, as neither indicated significant improvement in water quality in the Selja River for a five-year period (Vilbaste 2004). This is not surprising as Rott's index has been worked out for Alpine streams and ecological conditions are highly different in lowland and mountain regions.

Nine of the 16 indices calculated with OMNIDIA i.e. Biological Diatom Index (IBD), Descy's Index, Descy & Coste Diatom Index (CEC), Leclercq & Maquet Index (L\_M), Schiefele & Schreiner Index (SHE), Sladeczek's Index (SLA), Specific Pollution Sensitivity Index (SPI), Trophic Diatom Index (TDI), and Watanabe's Index, can be employed to estimate the water quality of Estonian running waters (Vilbaste 2004).

At the present, there are several different typologies of running waters in Estonia. So far only two of them take into account requirements set for biological elements (Järvekülg *et al.* 2003, Timm *et al.* 2003). According to the nonparametric Kruskal-Wallis ANOVA median test (Table 2), the response of all the studied diatom indices to the criterion of stream size in both typologies was nonexistent or very weak (Vilbaste *et al.* 2004). The diatom indices express the quality of stream water irrespective of the fact how large the stream is.

The hydromorphology of a stream site is an essential ecological factor for the stream biota. The whole benthic diatom flora is very different in soft bottom pools (with a viable motile epipellic component) and on the rapids (with prevalence of attached species) of the same stream. However, the variability of the epilithic diatom communities occurring on stones both in pools and on rapids is not very high as species of attached diatoms prevailed in both cases and the number of sporadic taxa is considerably lower compared with the soft bottom communities (Vilbaste 2001). It is possible to assess the ecological quality of water in running waters using benthic diatoms. However, changes in hydrology and channel structure are not necessarily evident from the composition and structure of benthic diatom assemblages (Eloranta and Soininen 2002).

According to the classification of Loigu and Leisk (2001), there exists a whole spectrum (five quality classes) of waters, from High to Bad, in the Estonian running waters. However, in this study the Poor waters and the Bad waters were in most cases differentiated only on the basis of the concentration of TotP or/and TotN.

Diatoms can tolerate much higher concentrations of phosphorus and nitrogen than those measured in this investigation. In a study by Kelly and Whitton (1995), the median content of FRP (Free Reactive Phosphorus) was  $79 \text{ mg m}^{-3}$  and the maximum content was  $2035 \text{ mg m}^{-3}$ ; in the present study, the median of FRP was  $26 \text{ mg m}^{-3}$  and the maximum  $409 \text{ mg m}^{-3}$ . Although TotP was used here instead of FRP in hydrochemical classification, the Spearman correlation between TotP and FRP was very high ( $R=0.93$   $p<0.001$ ), and hence both results are comparable. Thus diatoms can stand at least fivefold higher content of phosphorus than that measured in this study.

The status of water quality varies in a wide range among different European ecoregions. In Finnish rivers, the majority of TotP concentrations are lower than  $100 \text{ mg m}^{-3}$ , mostly  $< 50 \text{ mg m}^{-3}$  (Eloranta & Soininen 2002), in Iceland they never exceed  $50 \text{ mg m}^{-3}$ , while in Denmark TotP is higher than  $50 \text{ mg m}^{-3}$  in all streams (Indicators ... 1997). As the parameters of water quality are highly different, suitable diatom indices and their limit values for quality classes should be selected for each individual region.

## Conclusions

It is possible to use benthic diatoms in estimation of the water quality of running waters in Estonia. However, diatom indices are suitable for assessment of the ecological quality of water, but not for assessment of the hydromorphological status or the stream type. The most promising diatom indices for such purposes are Trophic Diatom Index and Watanabe Index.

## Acknowledgements

The research was supported by grant No 5429 of the Estonian Science Foundation.

## References

- Archibald R. E. M. 1972. Diversity in some South African diatom associations and its relation to water quality. *Water Research*. 6: 1229--1238.
- CEN 230. 2002. *Water quality- Guidance of standard for the routine sampling and pretreatment of benthic diatoms from rivers*. European Standard.
- Cox E. J. 1991. What is the basis of using diatoms as monitors of river quality? . *Use of Algae for Monitoring Rivers*. (Whitton B. A., Rott E. & Friedrich G. (toimetajad). Institut für Botanik, Universität Innsbruck, Innsbruck. 33--40.
- Descy J.-P. & Ector L. 1999. Use of diatoms for monitoring rivers in Belgium and Luxemburg. In *Use of algae for monitoring rivers III*. (Prygiel J., Whitton B. A. & Bukowska J. (toimetajad). Agence de l'Eau Artois-picardie, Douai. 128--137
- Directive 2000/60/EC of the European Parliament and of the council of 23 October 2000. *Official Journal of the European Communities*. 22.12.2000, 1--72.
- Indicators of the State of the Environment in the Nordic Countries*. 1997. Nordic council of Ministers. Stougaard Jensen/Scantryk A/S, Copenhagen
- Järvekülg R., Pall P., Piirsoo K., Timm H., Vilbaste S. Trei T. & Viik M. 2003. Typology of rivers in L. Peipsi-Võrtsjärv river basin, suggested by river biology working group. *Final report of the relevant system of indicators and criteria for evaluating the ecological status of very large nonstratified lake and its river basin in WFD context*. Nõges T. (toimetaja), MANTRA East, Tartu University, 76--81
- Jüttner I., Rothfritz H. & Ormerod S. J. 1996. Diatoms as indicators of river quality in the Nepalese Middle Hills with consideration of the effects of habitat-specific sampling. *Freshwater Biology*. 36: 475--486.
- Eloranta P. & Soininen J. 2002. Ecological status of some Finnish rivers evaluated using benthic diatom communities. *Journal of Applied Phycology*. 14: 1--7.
- Kelly M. G. 1998. Use of the trophic diatom index to monitor eutrophication in rivers. *Water Research*. 32: 236--242.
- Kelly M. G. & Whitton B. A. 1995. A new diatom index for monitoring eutrophication in rivers. *Journal of Applied Phycology*. 7: 433--444.

- Kolkwitz R. & Marsson M. 1908. Ökologie der pflanzlichen Saprobien. *Ber. Dt. Ges.* 26A: 505--519.
- Lecointe C., Coste M. & Prygiel J. 1993. "Omnidia" software for taxonomy, calculation of diatom indices and inventories management. *Hydrobiologia*, 269/270: 509--513.
- Lobo E., Katoh K. & Aruga Y. 1995. Response of epilithic diatom assemblages to water pollution in rivers in the Tokyo Metropolitan area, Japan. *Freshwater Biology*. 34: 191--204.
- Loigu E. & Leisk Ü. 2001. Classification of chemical status of rivers. In *Environmental impact and water management in a chachment area prespective*. Seepõld M. (toimetaja), Tallinn Technical University. 46--53.
- prEN 14407. Water quality- Guidance for the identification, enumeration and interpretation of benthic diatom samples from running waters.
- Prygiel J. & Coste M. 1996. Recent trends in monitoring French rivers using algae, especially diatoms. In *Use of algae for monitoring rivers II*. (Whitton B. A. & Rott E. toimetajad). Institut für Botanik, Universität Innsbruck. 87--96
- Prygiel J., Whitton B. A. & Bukowska J. (toimetajad) 1999. *Use of Algae for Monitoring Rivers III*. Agaence de l'Eau Artois-picardie, Douai.
- Round F. E. 1991. Diatoms in river water-monitoring studies. *Journal of Applied Phycology*. 3: 129--145.
- Timm H. 2003. *Euroopa Vee raamdirektiivile vastavad kvaliteedielemendid bioloogilise seisundi klassifitseerimiseks Eesti vooluveses*. Eesti Vabariigi Keskkonnaministeeriumi Info- ja Tehnokeskus, Tallinna Tehnikaülikool.
- Vilbaste S. 2001. Benthic diatom communities in Estonian rivers. *Boreal Environment Research*. 6: 191--203.
- Vilbaste S. 2004. Application of diatom indices in evaluation of water quality in Estonian running waters. *Proceedings of the Estonian Academy of Sciences. Biology. Ecology*. 53: 37--51.
- Vilbaste S., Järvekülg R., Pall P., Piirsoo K., Trei T. & Viik M. 2004. Diatom indices and stream typology in Estonia. *Oceanological and Hydrobiological Studies*. 33: 3--10.
- Whitton B. A. & Rott E. (toimetajad) 1996. *Use of Algae for Monitoring Rivers II*. Institut für Botanik, Universität Innsbruck, Innsbruck.
- Whitton B. A., Rott E. & Friedrich G. (toimetajad) 1991. *Use of Algae for Monitoring Rivers*. Institut für Botanik, Universität Innsbruck, Innsbruck.

Table 1. Spearman correlation coefficient between diatom indices and environmental factors, R  $\geq 0.5$  is in bold, ns – not significant

Diatom index	T	PH	Ox	Con	TotP	FRP	TotN	NO <sub>3</sub> -N	NO <sub>2</sub> -N	NH <sub>4</sub> -N	COD	BOD <sub>5</sub>	N/P
H'	0.26**	ns	-0.24**	ns	0.44***	0.38***	ns	-0.21*	ns	0.25**	ns	ns	-0.38***
I	0.20*	ns	-0.20*	ns	<b>0.54***</b>	<b>0.50***</b>	ns	ns	ns	0.21*	ns	0.20*	-0.40***
Tax	0.33***	ns	-0.27**	ns	ns	ns	-0.19*	-0.30***	ns	0.18	0.24**	ns	-0.20*
SPI	-0.35***	ns	0.24**	ns	<b>-0.55***</b>	-0.49***	ns	0.18*	-0.20*	ns	ns	-0.26**	0.46***
SLA	-0.29***	ns	ns	ns	<b>-0.51***</b>	-0.46***	ns	0.20*	-0.19*	-0.21*	ns	-0.24**	0.48***
Descy	ns	0.20*	ns	ns	ns	ns	ns	ns	ns	ns	ns	ns	ns
L-M	-0.29***	ns	0.19*	ns	-0.44***	-0.36***	ns	0.26**	-0.20*	-0.27**	ns	-0.18*	0.45***
GDI	-0.28**	ns	ns	ns	-0.24*	-0.21*	ns	ns	ns	ns	-0.19*	ns	0.24*
CEC	-0.31***	ns	ns	ns	<b>-0.54***</b>	-0.50***	ns	ns	-0.24**	-0.20*	ns	-0.27**	0.47***
SHE	-0.25**	ns	0.22**	ns	<b>-0.59***</b>	<b>-0.54***</b>	ns	0.18*	-0.23**	-0.21*	ns	-0.24**	0.52***
WAT	-0.31***	ns	ns	ns	<b>-0.52***</b>	-0.49***	ns	ns	-0.20*	ns	-0.24*	-0.25**	0.43***
IDAP	ns	0.34***	0.23**	0.34**	ns	ns	ns	0.18*	ns	ns	ns	ns	ns
TDI	ns	ns	ns	ns	0.28**	0.30***	ns	ns	ns	ns	ns	ns	-0.22*
IBD	-0.29***	-0.22**	ns	ns	<b>-0.56***</b>	<b>-0.54***</b>	ns	ns	-0.25**	-0.18*	ns	-0.25**	0.40***
Rott	-0.29***	-0.26**	ns	ns	-0.49***	<b>-0.50***</b>	ns	ns	-0.28**	ns	-0.25**	-0.29**	0.38***
EPI-D	-0.48***	-0.35***	ns	ns	-0.37***	-0.31***	ns	0.23**	ns	ns	-0.26**	-0.19*	0.39***

\*\*\* – p < 0.001

\*\* – p < 0.01

\* – p < 0.05

Table 2. Significance of differences in the diatom indices on the basis of criteria in two stream typologies according to the nonparametric Kruskal-Wallis ANOVA median test; significance is marked as \*\*\* – p< 0.001, \*\* – p< 0.01, \* – p< 0.05, ns – not significant

		Tax	H'	TDI	SPI	SLA	DESCY	L-M	CEC	SHE	WAT	IBD
<b>Index</b>												
Typology	Criterion											
Timm (2003)	Size (5)	ns	ns	ns	ns	ns	ns	ns	*	ns	ns	ns
	Geology (2)	*	*	ns	*	**	ns	***	**	ns	ns	*
	Flow velocity (2)	**	ns	ns	ns	ns	ns	ns	ns	ns	ns	ns
Järvekülg <i>et al.</i> (2003a)	Size (5)	ns	ns	ns	ns	ns	*	ns	ns	ns	ns	ns
	Geology (2)	ns	ns	ns	ns	ns	ns	ns	ns	ns	ns	ns
	Hydromorphology (2)	**	*	ns	ns	ns	ns	ns	ns	ns	*	*
	Water TEC (3)	*	ns	ns	**	*	ns	ns	**	ns	ns	**

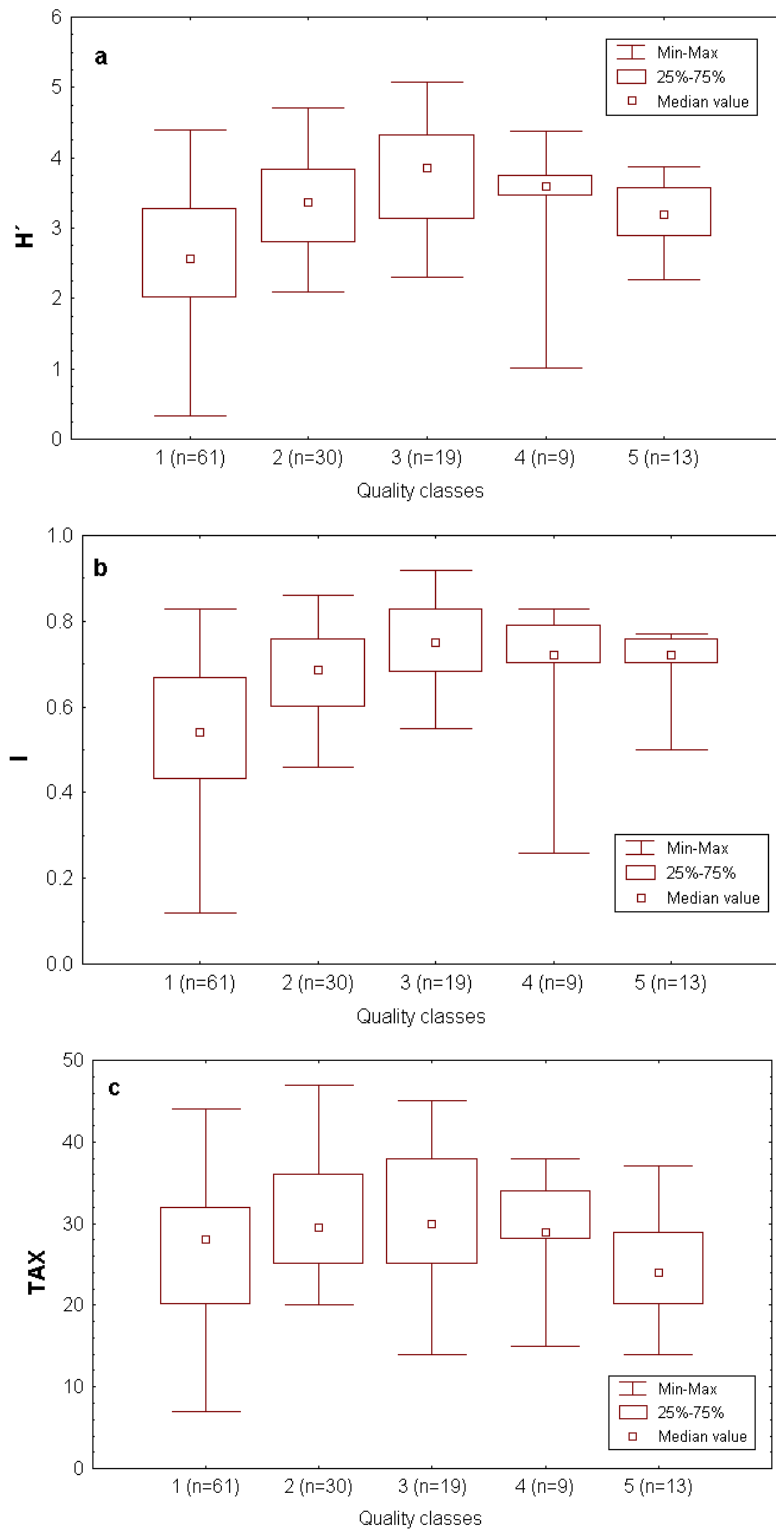

Figure 1. Differences in the values of (a) Shannon-Weaver diversity ( $H'$ ), (b) evenness ( $I$ ), and (c) species richness ( $Tax$ ) shown as boxplots by quality classes according to TotP (1 – High, 2 – Good, 3 – Moderate, 4 – Poor, 5 – Bad),  $n$  – number of samples.

# Estimation of periphytic growth on artificial substrates and sliming of nets

Sirpa Herve  
Central Finland Regional Environment Centre  
P.O.Box 110  
40101 Jyväskylä  
Finland  
sirpa.herve@ymparisto.fi

## Introduction

Eutrophication of water courses is a natural, but very slow phenomenon. Anthropogenic loading makes it more quickly, but still the early phases of eutrophication are in a slow line. However, when the eutrophication has once started to fasten, the process is very difficult to stop and return back the more oligotrophic status.

The eutrophication process in water courses starts with the increase of primary production on different surfaces, natural (e.g. stones) or artificial (e.g. the constructions of quays). So, the periphytic growth can be estimated in theory to be very sensitive for revealing the very first steps of eutrophication.

## Monitoring of periphyton

Periphytic growth can be measured from the natural surfaces, like stones, by taking samples during warm summer time. The species composition and the total periphytic biomass on certain area can be measured.

The advantage of natural surfaces is that the long-term development of e.g. species composition can be followed. The disadvantage is that it is difficult to find suitable sampling places e.g. on clay areas, and especially, how to take comparable samples.

## Artificial substrates

The use of artificial substrates in monitoring of periphytic growth has been studied in Finland since the 1980s, first in river monitoring, but later also in lake monitoring, especially in the cases, where the early steps of the eutrophication process has been caused by fish farming. First, different substrates, like glass, porcelain and plastic plates were studied. After these tests clean polycarbonate plates (150 mm x 100 mm x 2 mm) have been used in most of the monitoring programmes

The polycarbonate plates should be placed in the observation sites in special constructions for incubation to guarantee the comparability of results as regards e.g. the velocity in rivers, the light conditions and the depth (usually one meter in lakes and 0.5-1.0 m in rivers).

## Equipments for monitoring

There are special constructions for river monitoring (Figure 1) and for lake monitoring (Figure 2). The incubation time has been after testing phase fixed in Finland to be exact three weeks (21 days)

The suitable velocity in rivers should be some 0.2-0.3 m/s. The velocity should be measured in the beginning of the incubation and also at the end of the incubation period.

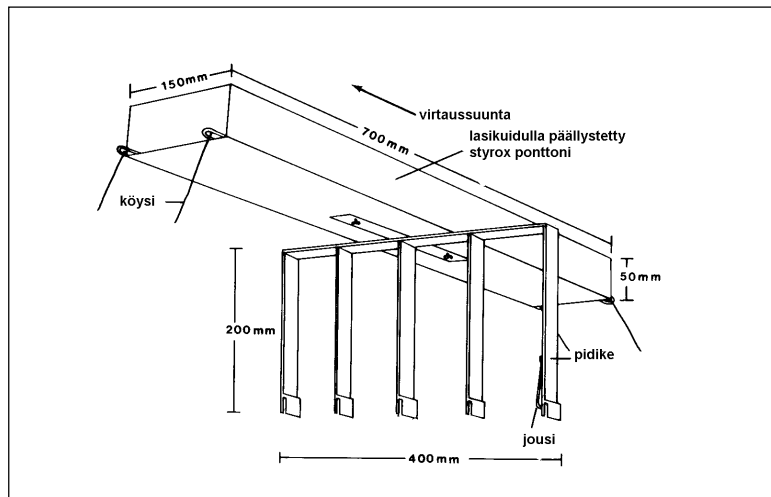

Figure 1. Construction for river monitoring of periphytic growth

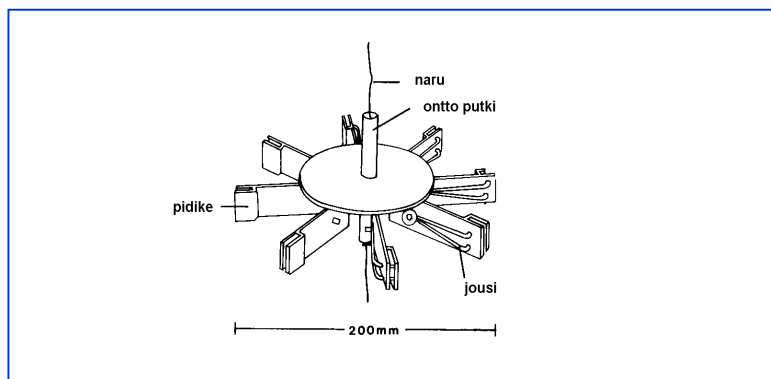

Figure 2. Construction for lake monitoring of periphytic growth

Periphytic growth is a very suitable variable in monitoring of the early phase of eutrophication (see Figure 3). The differences of periphytic growth values between oligotrophic area (site 1) and slight eutrophic area (site 4) can be more than tenfold, when the corresponding differences of phosphorus values are some 2-3-fold.

Several samples during the summer are, however, needed (like in phytoplankton studies). Several duplicate samples are also needed to improve the accuracy of information.

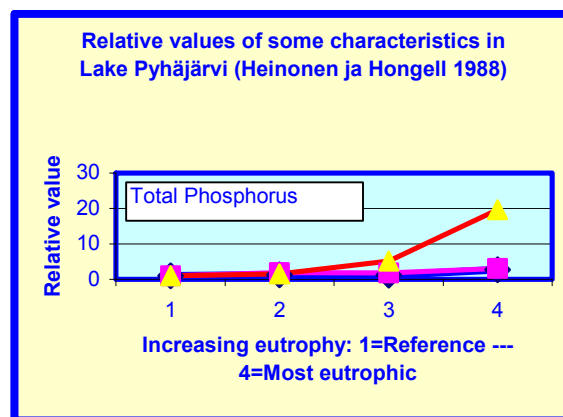

Figure 3. Relative values of total phosphorus (lowest line) and chlorophyll a (the following line) measured from water samples, and periphytic chlorophyll a values from plastic plates (the highest line)

## Sliming of nets

The principle to monitor the sliming of gill nets is to keep the standardised net (12 mm) in water of the lake concerned in standardised depth (one meter) and for a standardised incubation period (one day, 24 h). After incubation the contents of chlorophyll *a* and suspended solids in the net are measured. The results have been expressed in mg/g (net weight).

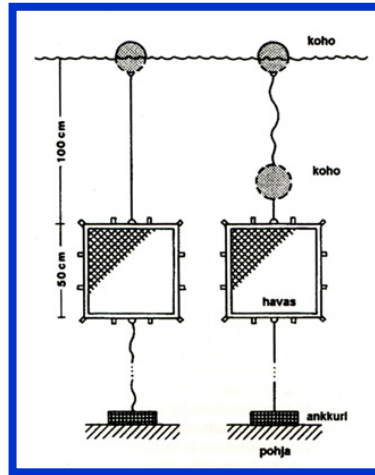

Figure 4. Construction for measuring the sliming of nets

## References

- Heinonen, P. & Hongell, H. 1988. Oulun läänin Pyhäjärven rehevöityminen kesällä 1985. Vesi- ja ympäristöhallinnon julkaisuja 27, 1-97. ISBN 951-47-2158-6, ISSN 0783-327X.
- Herve, S. & Heinonen, P. 2004. Perifytonmääritys keinoalustoilla. Julkaisussa: Ruoppa, M. & Heinonen, P. (toim.). 2004. Suomessa käytetyt biologiset vesitutkimusmenetelmät. Suomen ympäristö 682, 33-37. ISBN 952-11-1642-0, ISBN 952-11-1643-9 (pdf), ISSN 1238-7312
- Herve, S. & Heinonen, P. 2004. Verkkohavaksen limoittuminen. Julkaisussa: Ruoppa, M. & Heinonen, P. (toim.). 2004. Suomessa käytetyt biologiset vesitutkimusmenetelmät. Suomen ympäristö 682, 40-42. ISBN 952-11-1642-0, ISBN 952-11-1643-9 (pdf), ISBN 1238-7312.

# Zoobenthos monitoring in freshwaters and the challenge of the EU Water Framework Directive

Esa Koskenniemi  
West Finland Regional Environment Centre  
Box 262  
FI-65101 Vaasa  
Finland  
esa.koskenniemi@environment.fi

## 1 Introduction

Zoobenthos, i.e. benthic invertebrates, have been increasingly used in freshwater monitoring during the last decades (de Pauw & Hawkes 1993, Friberg & Johnson 1995, Johnson 1995, Knoben et al. 1995, Rosenberg & Resh 1993). Due to its large species richness covering all kind of freshwater habitats and to increased ecological knowledge on species responses to environmental conditions zoobenthos can now be used for different monitoring topics. These are for example eutrophication, acidification, changes in habitat structure and species diversity and toxicity.

Zoobenthos is rather easy to sample, and as sedentary and rather long-lived organisms they can reflect site-specific, long-term changes in nature. Additionally, there are many standards and guidances published i.e. for zoobenthos sampling and other steps important in the monitoring procedure. Hence, it is not surprising that zoobenthos studies play also an important role in current national and international freshwater monitoring (de Pauw & Hawkes 1993, Friberg & Johnson 1995, Bergström et al. 1995). To design future monitoring in the spirit of EU Water Framework Directive (WFD), zoobenthos seems to be in a key position assessing the ecological status and of freshwaters in Europe.

In general, most attention has been paid to rivers in freshwater monitoring in Europe. This is understandable, while rivers have traditionally been important for man throughout the whole Europe. The majority of lakes situates in the Nordic countries, but they are of increasing importance also in areas where they are rare and many larger lakes in Europe can even be regarded as unique ecosystems. In Europe, we have about half a million of lakes larger than 0.01 km<sup>2</sup>, and the total length of rivers exceeds 2 million kms (see Skriver 2001). It is therefore a big task to design a well functioning WFD monitoring strategy covering the whole Europe.

## 2 Monitoring design

A monitoring program can be seen as a process consisted of temporally subsequent steps (1-7, Norris & Georges 1993, Knoben et al. 1995, Koskenniemi 2000).

1. Environmental problem, scientific questions arising
2. Planning the monitoring (scientific, economical, organisational aspects)
  - 3a. Sample collection
  - 3b. Sample (preservation and) transport
  - 3c. Sample sorting and taxa identification
- 4a. Data recording, added by field measurement, background data
- 4b. Data transcription and entry
- 4c. Data analysis

5. Interpretation of results, conclusions
6. Publication, dissemination
7. Remedial measures (in nature, society), improved monitoring program (loop to stages 1 & 2)

The stepwise approach helps us to see where there are maybe something to improve in our monitoring plan, and we have realistic ideas about resource needs beforehand. In general, the equipment and procedures in the lake zoobenthos sampling and sorting are rather well standardized but other steps include more individualism and specific geographical-cultural features in monitoring. The sample stage (3a-c) is, however, usually the most critical step in zoobenthos studies (Resh & McElravy 1993).

The aim of monitoring determines the structure and contents of it. Two main types can be found: surveillance monitoring and compliance (statutory) monitoring (Rosenberg & Resh 1993, Powell 1995). In compliance, monitoring objectives are usually more clearly stated by norms and limits not allowed to be exceeded, and resembles the operational monitoring in the WFD terminology. To detect spatio-temporal differences in nature, the so-called BACI-approach is a good starting point: in a study, knowledge and data is needed Before and After as well as on both Control and Impact areas (Stewart-Oaten et al. 1986). As we know, there are often problems to get proper data before an event and control (reference) areas are in some cases nearly impossible to find. These aspects are now relevant in the WFD monitoring planning.

### 3 Zoobenthos and monitoring

For zoobenthos sampling, there are a number sampling devices in routine use for both lakes and rivers, and many of the methods are published as European (CEN) or international (ISO) standards. In lakes quantitative sampling is relatively use on soft bottoms (Ekman grabs, corers), but in the littoral area we have to use semi-quantitative or qualitative methods (hand nets, picking the stones, hydraulic suction pumps). In rivers, quantitative sampling is often difficult. Kick-net sampling in riffles and rapids is certainly the most useful method to study community structure in smaller and middle-size rivers, but many problems arise with larger rivers, where e.g. colonizations trays or drift sampling (usually exuviae) can be possible methods. Surprisingly, the number of replicate samples needed (upto 10) for good statistical comparisons may be high even in soft bottom studies (e.g. Veijola et al. 1996).

Sorting of zoobenthic samples is often time consuming especially in samples with high volume of sieving rests. Random subsampling can help to save time and is highly recommended, but should be tested for reliability. In taxonomic identification, problems may arise with certain invertebrate groups (e.g. small molluscs, Dipteran insects) and also the literature used may vary in different studies. Also here there is still need of harmonization work in future (see e.g. Skriver 2001).

A large variety of zoobenthos metrics are possible to use in freshwater classification (see Knoben et al. 1995, Rosenberg & Resh 1993). From the point of view of the WFD, the Annex V in the Directive gives the starting point. For instance, many biotic indices are available (like the BQI for lakes and the ASPT for rivers, as examples), but they may suffer from geographical restrictions or unreliable taxa scores. In future, the most important point is still, that the steps before classification will allow the comparability of the results.

## 4 Towards the WFD monitoring

The WFD approach calls for a monitoring network covering all freshwater types and for classification, knowledge on reference and impacted sites. Zoobenthos studies have successfully been used in studies to detect environmental problems like eutrophication, acidification and toxicity. The main pressures to be monitored are well listed in the Directive Annex II. All the biological elements are now included into the monitoring and classification procedure, with the idea that any kind of pressure can be detected in our freshwaters. Several guidance manuals to help WFD monitoring planning have already been published (see for instance, [http://www.emwis.org/WFD/about\\_cis.htm](http://www.emwis.org/WFD/about_cis.htm)) and on-going research projects (AQEM, STAR, FAME, EUROLAKES) support this work. We have, however, still a lot of harmonisation work left especially when the EU area tends to enlarge in future.

## References

- Bergström, I., Mäkelä, K. & Starr, M. 1995 (eds.), Integrated monitoring in Finland. UN ECE Report, the Ministry of the Environment, 138 pp. Forssa, Finland.
- De Pauw, N. & Hawkes, H. A. 1993: Biological monitoring of river water quality. - In: Walley, W.J. & Judd, S. (eds.), River water quality monitoring and control: 87-111. Aston Univ., U.K.
- Friberg, N. & Johnson, R.K. (eds.) 1995: Biological monitoring of streams. - TemaNord 1995:640. Nordic Council of Ministers.
- Johnson, R.K. 1995: The indicator concept in freshwater biomonitoring. In: Cranston, P. (ed.), Chironomids: from genes to ecosystems:11-27. Proc. 12 th Int.Chir.Symp., CSIRO Publ., Canberra, Australia.
- Knoben, R.A.E., Roos, C. & van Oirschot, M.C.M. 1995: Biological assessment methods for watercourses. - UN/ECE Task Force on Monitoring and Assessment 3. Lelystad, the Netherlands.
- Koskeniemi, E. 2000: Use and applicability of zoobenthic communities in lake monitoring. - In: Heinonen, P., Zigliio, G. & van der Beken, A. (Eds.), Hydrological and Limnological Aspects of Lake Monitoring, pp. 106-117. John Wiley & Sons.
- Norris, R.H. & Georges, A. 1993: Analysis and interpretation of benthic macroinvertebrate surveys. - In: Rosenberg, D.M. & Resh, V.H. (eds), Freshwater biomonitoring and benthic macroinvertebrates: 234-286. Chapman & Hall, New York - London.
- Powell, M. 1995: Building a national water quality monitoring program. - Env. Science & Technol. 29: 458-463.
- Resh, V.H. & McElravy, E.P. 1993: Contemporary quantitative approaches to biomonitoring using benthic macroinvertebrates. - In: Rosenberg, D.M. & Resh, V.H. (eds), Freshwater biomonitoring and benthic macroinvertebrates: 159-194. Chapman & Hall, New York - London.
- Rosenberg, D.M. & Resh, V.H. 1993: Introduction to freshwater biomonitoring and benthic macroinvertebrates. - In: Rosenberg, D.M. & Resh, V.H. (eds), Freshwater biomonitoring and benthic macroinvertebrates: 1-9. Chapman & Hall, New York - London.
- Skriver, J. 2001: Biological monitoring in Nordic rivers and lakes. - TemaNord 2001:513. Nordic Council of Ministers.
- Stewart-Oaten, A., Murdoch, W.W. & Parker, K.R. 1986: Environmental impact assessment: "pseudoreplication" in time?. - Ecology 67:929-940.
- Veijola, H., Meriläinen, J.J. & Marttila, V. 1996: Sample size in the monitoring of benthic macrofauna in the profundal of lakes: evaluation of the precision of estimates. - Hydrobiologia 322:301-315.

- Walker, I.R. 1993: Paleolimnological biomonitoring using freshwater benthic macroinvertebrates. - In: Rosenberg, D.M. & Resh, V.H. (eds), Freshwater biomonitoring and benthic macroinvertebrates: 306-343. Chapman & Hall, New York - London.
- Warwick, W.F. 1991: Indexing deformities in ligulae and antennae of Procladius larvae (Diptera: Chironomidae): application to contaminant-stressed environments. - Can.J.Fish.Aquat.Sci. 48:1151-1166.
- Wiederholm, T. 1980: Use of benthos in lake monitoring. - J.Wat.Pollut.Cont.Fed. 52:537-547.
- Internet: [http://www.emwis.org/WFD/about\\_cis.htm](http://www.emwis.org/WFD/about_cis.htm) (Guidance WFD manuals)

# Benthic invertebrates as a tool to classify ecological status of inland waters. Estonian experiences

Henn Timm  
Institute of Zoology and Botany  
Estonian Agricultural University  
61101 Võrtsjärv Limnological Station  
Rannu, Tartumaa, Estonia  
htimm@zbi.ee

## Introduction

According to the European Water Framework Directive (2000), the composition and the abundance of the benthic invertebrate fauna are considered among the biological quality elements required for classification of the ecological status of surface water bodies. Estonia as a whole belongs to the Baltic ecoregion (No. 15), with a prevailing altitude lower than 200 m. The area was significantly influenced by a glacier sheet until ca 10,000 years ago. After that, the tectonic uprise of the Earth's crust occurred, particularly in the western (seaward) part of the country. The sedimentary cover of Northern, Western and Central Estonia consists mainly of Ordovician and Silurian carbonate. On the other hand, almost the whole of Southern Estonia is a region of Devonian sandstone.

Estonia belongs to the area of mixed forests of the temperate zone, bordering on taiga. In comparison with the other European areas, it excels by a quite large proportion of raised bogs and forests (Estonian Nature 1995). Altogether, 25 local landscape regions have been distinguished here (Arold 2001), including six uplands and nineteen lowlands.

Most studies of freshwater macroinvertebrates in Estonia were conducted at first in Tartu University (1950s), later in the Institute of Zoology and Botany (IZB). The IZB was formed as a part of the Estonian Academy of Sciences; since 1997 it is a branch of the Agricultural University in Tartu.

## Offshore areas in lakes

Like in the other countries, systematic sampling of freshwater macroinvertebrates in Estonia was induced by a traditional practice in marine biology. Hence, the attention in freshwaters was first also directed to offshore areas that usually prevail in lake benthal and possess similar habitats with sea bottom (deep water, soft sediment). In 1950s and 1960s, the general aim of freshwater benthological studies was to give a background for the fishery potential of waterbodies.

The first attempt to use macrozoobenthos as an indicator of waterbodies was made by Õ. Tõlp (1956), using Ekman samples for calculation of saprobic index in the Emajõgi River. Encouraged by intensive typological studies of Estonian lakes in 1970s (Mäemets 1977), T. Timm *et al.* (1982) characterized macrozoobenthos communities in different lake types. However, only few macrozoobenthic taxa in offshore areas had indicatory value to make proper conclusions, and the different lake types were indistinguishable in stratified profundal habitat. The use of indication systems elaborated elsewhere (Wiederholm 1980) failed because the dissimilarities in fauna and/or lake morphometry.

The macroinvertebrate database collected from offshore areas, or deeper littoral, using Ekman-type samplers during 1951-2004 includes now more than 5000 hauls from hundreds of small lakes. In

addition, regular yearly samples starting from early 1960s were collected from the two largest Estonian lakes (Peipsi-Pihkva, over 6000 hauls) and Võrtsjärv, over 9000 hauls). The data of two large lakes were summarized in several articles (Kangur *et al.* 1988; T. Timm *et al.* 1996a, 1996b, 2001). However, long-term changes rather than biological quality was the subject of these studies.

Recently, relationships between lake stratification and macrozoobenthos in small lakes, as well as the changes of macrozoobenthos due to anthropogenic eutrophication in 1970s and 1980s was estimated (Timm *et al.* 2003, in press; Timm *et al.*, in prep.). The offshore data from small lakes are involved in the scientific project "Formation and changes of the biological diversity under the human impact in different lake types" (Estonia-Denmark-Netherlands, 2003-2007).

## Shallow areas (streams and lake littoral)

Intentional collection of macroinvertebrates from running waters in order to estimate biological quality was started in the IZB at the end of 1980s, by two working groups (Võrtsjärv Limnological Station, and the stream ecology group in Tartu). In small lakes, the corresponding regular works began in 1994. Compared with offshore areas of lakes and large rivers, shallow streams and lake littoral are easy to sample, and there occur a variety of taxa that are sensitive to different kinds of environmental stress. Also, several well-working indicator systems that can be effectively tested in Estonian conditions are elaborated (see Johnson *et al.* 1993 for overview). Moreover, samples from shallow areas enable direct comparison between standing and running waters.

Three main sampling strategies were used in shallow freshwaters during 1985-2004. In the wide sense, they resemble the three levels of rapid bioassessment protocols described by Plafkin *et al.* (1989) in a monitoring program system for North American streams.

For simple qualitative samples (collected mainly in 1985-1995 but also later in several cases), the whole sampling area and the proportion of different substrates were not standardized. The animals were picked directly from hard substrates, or were examined after being capturing in a handnet. Sampling was continued until no new taxa were detected, or all material was sorted in the laboratory.

The Danish collection method was originally designed to calculate the Danish Stream Fauna Index. According to Skriver *et al.* (2000), the samples were taken with a standard handnet. Sampling was done along three transects across the stream. The kick samples were supplemented by hand-picking from submerged stones and large-sized wooden debris. Compared with simple qualitative samples, standardization of the sampling area for the most typical bottom was the most important difference. Such samples originate mainly from the period of 1996-1999.

According to the standard semi-quantitative technique EN 27828 (Johnson 1999), the samples were collected using standardized kick sampling with a handnet. Five 1 m kick samples were taken from an uniform (preferably riffle) bottom at each site. In addition, a qualitative sample was taken from all available substrates (Medin *et al.* 2001). Unlike in the case of the two previous methods, the collected animals were fixed together with sieving residues (debris, sand, pebbles) and sorted in the laboratory. For Estonian streams, such a technique has been used regularly in ordinary monitoring since 2000. In lakes without any hard bottom, vertical net sweeps on stable, steep plant-root edges (preferably quagmire margins and *Carex* tufts) were used instead of kicking.

Seven quality indices were calculated for running waters [total abundance, total taxa richness; Ephemeroptera, Plecoptera and Trichoptera taxa richness (EPT); Shannon diversity, British Average Score Per Taxon (ASPT), Danish Stream Fauna Index (DSFI), and Swedish acidity index], and

six indices (all above except the Danish index) for standing waters. Such indices express several aspects of general ecological quality, organic pollution and acidity level. At the same time, Järvekülg (2001) concluded that the saprobic index alone could not well distinguish unpolluted sites from the polluted sites in Estonian streams.

Calculation of several indices instead of one metric requires relatively short extra-time compared with sorting and identification processes. For example, AQEM (The Development and Testing of an Integrated Assessment System for the Ecological Quality of Streams and Rivers throughout Europe using Benthic Macroinvertebrates) project has developed a software that is able to calculate a lot of indices, scores and ratios. On the basis of the most suitable metrics, several European regions can set now multimetric indices that describe the local levels of biological quality the best (AQEM Consortium 2002).

The number of samples in the database of Limnological Station from shallow areas of streams and lakes in Estonia exceeds 2500. Many of these samples include several replications of semi-quantitative kick-samples, as well as the concurrent qualitative samples. The stream ecology group of Institute of Zoology and Botany has collected over 600 qualitative samples from running waters.

Macroinvertebrate fauna and composition as a basis for typology and/or an indicator of impairment in Estonian freshwaters has been a subject of investigation during last years (Järvekülg 2001; Timm 1997 & 2003; Timm *et al.* 1999 & 2001).

The typical common mesohabitats for macroinvertebrates in Estonian running waters were stones/gravel and sand, while quagmire edges and sand/detritus prevailed in standing waters. Stony bottom that should be preferred for sampling in the lake littoral was quite rare in Estonia.

In order to establish the reference levels for several indices in different mesohabitats, median values of the metrics characterizing high biological status were calculated according to Wallin *et al.* (2003). Altogether, reference conditions were given for six indices in streams (considering catchment area, velocity *resp.* bottom type, and baserock type) and five indices in lakes (considering limnological type, bottom type, and lake area) (Timm, 2003).

While bottom type in streams was significant only for EPT richness, and baserock type influenced substantially only the acidity index, the catchment area revealed significant effect on all studied metrics (except abundance, which was not analyzed in details). Among the preliminary catchment area classes used here, the category of <math> < 100 \text{ km}^2 </math> was significant almost in all cases (except the DSFI), indicating the particular nature of the smallest streams. For instance, this threshold was the only factor, to which the total taxa richness and ASPT index in streams were sensitive. For EPT richness and Shannon diversity, also the 1000 km<sup>2</sup> catchment area limit was considered meaningful. In case of DSFI, rivers with a catchment area larger than 2500 km<sup>2</sup> were substantially different from the smaller ones (unfortunately, the number of measurements was low). Finally, 250 km<sup>2</sup> catchment area instead of the common 100 km<sup>2</sup> limit seemed to be ecologically significant for acidity index in limestone areas.

It must be stressed that the stream catchment area classes used here were not verified *a priori* as meaningful units but served only as more or less reasonably chosen categories. Substrate type (stones or gravel versus sand or clay) as a surrogate of current velocity was successfully used here. This enabled to estimate mean normal velocity reliably even during occasional rapid flows or moderate droughts.

In lakes the limnological type was responsible for significant natural differences in all five indices studied. The type of substrate (distinguished here only among small hard-water lakes) influenced

significantly EPT richness, Shannon diversity and acidity index. The large area of the lakes Peipsi and Võrtsjärv might probably cause lower taxa richness and Shannon diversity in these lakes compared with other hardwater lakes.

Although all streams in Baltic states (among them in Estonia) were considered to belong to a single ecoregion where only three baserock subtypes (limestone, sandstone and peat) occur (Water Framework Directive, 2000), there appeared numerous doubtful cases, which need more specified approach. Many streams undoubtedly feed on two or more different baserock subtypes. Second, baserock alone cannot determine stream biota reliably. For example, several softwater streams and softwater humic lakes occur in limestone-based areas. On the contrary, in sandstone-based areas, the alkaline moraine surface occasionally influences stream chemistry much more than the baserock type. Therefore, in addition to baserock, the local landscape region as a separate variable should be taken into consideration.

Before using the preliminary type-specific conditions as reference standards, the general natural stream types for Estonia must be first specified, including those of peaty areas, missing in this work. Secondly, the proper types with insufficient (or missing) sample number both in streams and lakes must be provided with data to a statistically acceptable level (at least 10 measurements for each combination). Otherwise, natural variability of indices can mask the changes in macroinvertebrate communities, generated by slight or moderate impairment (Sandin & Johnson, 2000). Nevertheless, in the waterbodies of some types (particularly very large lakes and rivers), true reference conditions may not be met any more.

In September 2004, an intercalibration project between macroinvertebrate experts of Baltic States was conducted on some South Estonian waterbodies. Two stream sites, presumably possessing good or high quality, one stream site of moderate quality, and one lake littoral site of good quality were sampled by four teams from three countries (Estonia, Latvia, Lithuania). The detailed results will be published in the near future.

It was obvious that the quality of waterbodies in the sites, estimated on macroinvertebrate composition, was generally not influenced by the differences of sampling methods, identification level, or quality indices used by different teams. However, the quality at all three stream sites was higher than expected (high instead of good/high, good instead of moderate), according to the criteria discussed above. Nevertheless, the term "reference conditions" in Timm (2003) indicated minimally disturbed areas rather than pristine waterbodies. Secondly, the borders between quality classes (85% of reference level as the high/good border, 70% as the good/moderate border *etc.*) might be too loose to detect smaller perturbations. Thirdly, the real quality borders are probably not universal for all metrics. For example, according to Medin *et al.* (2001), 90% instead of 85% of the reference level was considered high/good border, as well as 80% instead of 70% as the good/moderate border for Swedish freshwaters. For particular metrics such as taxa richness and EPT richness, the good/moderate border was considered 75%.

Compounding this issue is that a large material of macroinvertebrates was collected in Estonian freshwaters during a half of century, although shallow areas rich of taxa have received attention mainly during the last decade. To classify ecological status of inland waters in Estonia, the datasets should be first completed with missing waterbody types and habitats. To establish the real class boundaries, other than between high and good status, the corresponding database of disturbed waterbodies must be created and analyzed in similar way.

## References

- AQEM Consortium (2002). Manual for the application of the AQEM system. A comprehensive method to assess European streams using benthic macroinvertebrates, developed for the purpose of the Water Framework Directive. Version 1.0, February 2002.
- Arold I., 2001. Distribution of landscapes in Estonia (in Estonian). Tartu Ülikooli Kirjastus, 72 pp.
- Estonian Nature, 1995 (in Estonian). Ed. A. Raukas. Tallinn, "Valgus"/ Eesti Entsüklopeediakirjastus, 606 pp.
- Järvekülg A., 2001. Zoobenthos of rivers (in Estonian). In: Estonian Rivers (Ed. A. Järvekülg). Tartu Ülikooli Kirjastus, pp. 158-186.
- Johnson R.K., 1999. Benthic macroinvertebrates. In: *Bedömningsgrunder för miljö kvalitet. Sjöar och vattendrag. Bakgrundsrapport 2. Biologiska parametrar* (Ed. by Torgny Wiederholm). Naturvårdsverket Förlag, pp. 85-166.
- Johnson R.K., Wiederholm T., Rosenberg D.M., 1993. Freshwater biomonitoring using individual organisms, populations, and species assemblages of benthic macroinvertebrates. In: *Freshwater biomonitoring and benthic macroinvertebrates, 1993*. Eds. D.M. Rosenberg & V.H. Resh. New York - London, pp. 40-158
- Kangur K., Timm H., Timm T., Timm V., 1998. Long-term changes in the macrozoobenthos of Lake Võrtsjärv. *Limnologica* 28: 75-83.
- Mäemets A., 1977. Lakes of the Estonian S.S.S.R. and their protection (in Estonian). Tallinn, "Valgus", 263 pp.
- Medin M., Ericsson U., Nilsson C., Sundberg I., Nilsson P.-A., 2001. *Bedömningsgrunder för bottenfaunaundersökningar*. Medins Sjö- och Åbiologi AB. Mölnlycke, 12 pp.
- Plafkin J.L., Barbour M.T., Porter K.D., Gross S.K., Hughes R.M., 1989. Rapid bioassessment protocols for use in streams and rivers: benthic macroinvertebrates and fish. EPA Report N 10714.02 (U.S.A.).
- Sandin L., Johnson R.K., 2000. Ecoregions and benthic macroinvertebrate assemblages of Swedish streams. *Journal of the North American Benthological Society* 19: 462-474.
- Skriver J., Friberg N., Kirkegaard J., 2000. Biological assessment of watercourse quality in Denmark: Introduction of the Danish Stream Fauna Index (DSFI) as the official biomonitoring method. *Verhandlungen der Internationalen Vereinigung für Limnologie* 27: 1822-1830.
- Timm H., 1997. Ephemeroptera and Plecoptera larvae as environmental indicators in running waters of Estonia. In: P. Landolt & M. Sartori (Eds). *Ephemeroptera & Plecoptera: Biology-Ecology-Systematics*. MTL, Fribourg, pp. 247-253.
- Timm H., 2003. Typology and classification of freshwaters in Estonia: preliminary results using shallow-water macroinvertebrates. In: *How to assess and monitor ecological quality in freshwaters*. M. Ruoppa, P. Heinonen, A. Pilke, S. Rekolainen. H. Toivonen & H. Vuoris-to (Eds.). *TemaNord* 2003: 547, pp. 164-169.
- Timm H., Ivask M., Möls T., 2001. Response of macroinvertebrates and water quality to long-term decrease in organic pollution in some Estonian streams during 1990-1998. *Hydrobiologia*, 464: 153-164.
- Timm H., Möls T., Kangur K., Timm T., 1999. Littoral macroinvertebrates in some small lakes of Estonia. In: *Biodiversity in benthic ecology. Proc. from Nordic Benthological Meeting in Silkeborg, Denmark, 13-14 November 1997*. NERI Technical Report, No. 266: 133-139.
- Timm H., Möls T., Timm T., 2003. Macro- and meiozoobenthos in some small stratified lakes of Estonia. *Aquatic Ecology* (in press).
- Timm H., Möls T., Timm T. (in prep.). Effects of long-term non-point eutrophication on the abundance and biomass of macrozoobenthos in small lakes of Estonia.
- Timm T., Kangur K., Timm H., Timm V., 1996. Macrozoobenthos of Lake Peipsi-Pihkva: taxonomical composition, abundance, biomass, and their relations to some ecological parameters. *Hydrobiologia* 338: 139-154.

- Timm T., Kangur K., Timm H., Timm V., 1996. Macrozoobenthos of Lake Peipsi-Pihkva: long-term biomass changes. *Hydrobiologia* 338: 155-162.
- Timm T., Kangur K., Timm H., Timm V., 2001. Zoobenthos. In: Lake Peipsi. Flora and Fauna (Eds. E. Pihu, J. Haberman). Sulemees Publishers, Tartu, 82-99.
- Timm T., Timm V., Kangur K., Tõlp Õ., 1982. Evaluation of the condition of Estonian lakes by zoobenthos (in Estonian). In: Eesti NSV järvede nüüdisseisund. Tartu, 134-141.
- Tõlp Õ., 1956. On the benthos of the Emajõgi River (in Estonian). *Loodusuurijate Seltsi Aastaraamat* 49: 143-161.
- Wallin M., Wiederholm, T. & Johnson R., 2003. Guidance on establishing reference conditions and ecological status class boundaries for inland surface waters. CIS Working Group 2.3 – REFCOND, 7<sup>th</sup> version.
- Water Framework Directive, 2000. The European Parliament and the Council of the European Union. Directive 2000/60/EC.
- Wiederholm T., 1980. Use of benthos in lake monitoring. *Journal of Water Pollution Control Federation* 52: 537-547.

# A practical guide for sampling methods of wastewater

Bruno Lemièrè  
BRGM (French Geological Survey)  
EPI - Environment & Process Division  
BP 6009, 3 Av. C. Guillemin  
45060 ORLEANS Cedex 2  
France  
e-mail: b.lemiere@brgm.fr

## 1 Introduction

The presentation has been made in the waste water sampling seminar according to the work plan of the LIFE-Environment project “Virus and Peipsi Catchment Area Management Plan” (LIFE00 ENV/EE/000925) following B. Lemièrè Mission in Tallinn.

The aim of the seminar was training of people from local Environment Services to take waste water samples and to use the seminar materials as a “key-entry” to wastewater sampling handbook.

### 1. 1 Definitions from Urban Waste Water Treatment Directive and Estonian legal acts

European Union definitions for **wastewater** are given in the Directive 91/271/EEC on Urban Waste Water Treatment, amended by the Directive 98/15/EEC:

[http://europa.eu.int/comm/environment/water/water-urbanwaste/index\\_en.html](http://europa.eu.int/comm/environment/water/water-urbanwaste/index_en.html)

- 'urban waste water' means domestic waste water or the mixture of domestic waste water with industrial waste water and/or run-off rain water. Urban wastewater collects runoff from household and SMEs, and street rainfall;
- 'domestic waste water' means waste water from residential settlements and services which originates predominantly from the human metabolism and from household activities;
- 'industrial waste water' means any waste water which is discharged from premises used for carrying on any trade or industry, other than domestic waste water and run-off rain water;

This Directive contains also the definition for **Sensitive Areas**, and establishes requirements in terms of discharge to the environment and pollution load. These are based on the following indicator, applicable to all types of wastewater:

- 1 p.e. (population equivalent)' means the organic biodegradable load having a five-day biochemical oxygen demand (BOD<sub>5</sub>) of 60 g of oxygen per day.

A water body must be identified as a sensitive area if it falls into one of the following groups:

- a) natural freshwater lakes, other freshwater bodies, estuaries and coastal waters which are found to be eutrophic or which in the near future may become eutrophic if protective action is not taken (i.e., removal of phosphorus and of nitrogen)
- b) surface freshwaters intended for the abstraction of drinking water which could contain more than the concentration of nitrate required of category A3 water within the meaning of Article 2 of Directive 75/440/EEC, 16.06.1975.
- c) areas where further treatment than that prescribed in Article 4 of this Directive is necessary to fulfil Council Directives.

The Estonian definition for wastewater is provided in the Water Act (RT I 1994, 40, 655; 1996, 13, 241; 1998, 2, 47; 61, 987; 1999, 10, 155; 54, 583; 95, 843; 2001, 7, 19; 42, 234; 50, 283; 94, 577; 2002; 1, 1)

According to section 8 of § 2 of the Water Act “waste water” means water which is damaged beyond the level of harmlessness and which requires purification, or effluent or contaminated rain water.

## 1.2 Urban Wastewater Contaminants

All the inorganic, organic and biological contaminants may be found in wastewater. Their classification is mainly based on their chemistry, but may be based on the available analytical methods, or on their toxicity and potential risk.

The contaminants and substances specifically addressed for in the Directive 91/271/EEC on Urban Waste Water Treatment are:

- BOD<sub>5</sub>,
- COD,
- Total suspended solids,
- Nitrogen (N),
- Phosphorus (P).

This selection reflects that the key issue about wastewater is eutrophication.

Beyond these, some of the most common contaminants in urban wastewater are:

- Detergents and surface-active agents
- Metals: Pb, Zn, (As, Cu, Cr); cyanide
- Organic: PAHs (rainfall from fumes), phtalates, MTBE (car fuel), phenols, chlorophenols; other water-soluble chemicals
- Plant protection products from gardens and collective green areas.

Normative requirements for discharges of BOD<sub>5</sub>, COD, total suspended solids, N and P, from the Directive 91/271/EEC are presented in Tables 1 and 2.

Table 1: Requirements for discharges from urban waste water treatment plants subject to Articles 4 and 5 of the Directive. The values for concentration or for the percentage of reduction shall apply.

Parameters	Concentration	Minimum percentage of reduction (1)	Reference method of measurement
Biochemical oxygen demand (BOD <sub>5</sub> at 20 °C) without nitrification (2)	25 mg/l O <sub>2</sub>	70-90 40 under Article 4 (2)	Homogenized, unfiltered, undecanted sample. Determination of dissolved oxygen before and after five-day incubation at 20 °C ± 1 °C, in complete darkness. Addition of a nitrification inhibitor
Chemical oxygen demand (COD)	125 mg/l O <sub>2</sub>	75	Homogenized, unfiltered, undecanted sample Potassium dichromate
Total suspended solids	35 mg/l 35 under Article 4 (2) (more than 10 000 p.e.) 60 under Article 4 (2) (2 000-10 000 p.e.)	90 (3) 90 under Article 4 (2) (more than 10 000 p.e.) 70 under Article 4 (2) (2 000-10 000 p.e.)	- Filtering of a representative sample through a 0,45 in filter membrane. Drying at 105 °C and weighing - Centrifuging of a representative sample (for at least five minutes with mean acceleration of 2 800 to 3 200 g), drying at 105 °C and weighing

(1) Reduction in relation to the load of the influent.

(2) The parameter can be replaced by another parameter: total organic carbon (TOC) or total oxygen demand (TOD) if a relationship can be established between BOD<sub>5</sub> and the substitute parameter.

(3) This requirement is optional.

Analyses concerning discharges from lagoons shall be carried out on filtered samples; however, the concentration of total suspended solids in unfiltered water samples shall not exceed 150 mg/l.

Table 2: Requirements for discharges from urban waste water treatment plants to sensitive areas which are subject to eutrophication as identified in Annex II.A (a). One or both parameters may be applied depending on the local situation. The values for concentration or for the percentage of reduction shall apply.

Parameters	Concentration	Minimum percentage of reduction (1)	Reference method of measurement
Total phosphorus	2 mg/l P (10 000 - 100 000 p. e.) 1 mg/l P (more than 100 000 p. e.)	80	Molecular absorption spectrophotometry
Total nitrogen (2)	15 mg/l N (10 000 - 100 000 p. e.) 10 mg/l N (more than 100 000 p. e.) (3)	70-80	Molecular absorption spectrophotometry

- (1) Reduction in relation to the load of the influent.
- (2) Total nitrogen means: the sum of total Kjeldahl-nitrogen (organic N + NH<sub>3</sub>), nitrate (NO<sub>3</sub>)-nitrogen and nitrite (NO<sub>2</sub>)-nitrogen.
- (3) Alternatively, the daily average must not exceed 20 mg/l N. This requirement refers to a water temperature of 12° C or more during the operation of the biological reactor of the waste water treatment plant. As a substitute for the condition concerning the temperature, it is possible to apply a limited time of operation, which takes into account the regional climatic conditions. This alternative applies if it can be shown that paragraph 1 of Annex I.D is fulfilled.

For the other contaminants:

- Detergents and surface-active agents
- Metals,
- Organic,
- Plant protection products,

no specific requirement results from the Directive itself, the applicable guidelines are those for surface water contamination, for river or lake water downstream full homogeneisation of a wastewater input.

### 1.3 Industrial wastewater contaminants

Contaminants to be found in industrial wastewater are highly dependent upon the industry type (Table 3).

Table 3: Types of industrial activities affecting wastewater

<b>adhesives</b>	<b>pulp &amp; paper</b>
<b>feather tanning and finishing</b>	<b>textile mills</b>
<b>soaps &amp; detergents</b>	<b>timber</b>
<b>aluminum forming</b>	<b>coal mining</b>
<b>battery manufacturing</b>	<b>ore mining</b>
<b>soil coating</b>	<b>petroleum refining</b>
<b>copper forming</b>	<b>steam electric</b>
<b>electroplating</b>	<b>organic chemicals</b>
<b>foundries</b>	<b>pesticides</b>
<b>iron &amp; steel</b>	<b>pharmaceuticals</b>
<b>non-ferrous metals</b>	<b>plastic &amp; synthetic materials</b>
<b>photographic supplies</b>	<b>rubber</b>
<b>plastics processing</b>	<b>auto &amp; other laundries</b>
<b>porcelain enamel</b>	<b>mechanical products</b>
<b>gum &amp; wood chemicals</b>	<b>electric &amp; electronic components</b>
<b>paint &amp; ink</b>	<b>explosives manufacturing</b>
<b>printing &amp; publishing</b>	<b>inorganic chemicals</b>

The type of contaminants associated with each sector may be found in sector-specific literature. See for instance:

- sector booklets in the Pollution Prevention and Abatement Handbook, World Bank, 1997 - [www-esd.worldbank.org/pph/toc.htm](http://www-esd.worldbank.org/pph/toc.htm),
- US- EPA Sector Notebooks, containing information on selected major industrial groups. These notebooks, which focus on key indicators that holistically present air, water, and land pollutant release data, have been thoroughly reviewed by experts from both inside and

outside the EPA:

[www.epa.gov/Compliance/resources/publications/assistance/sectors/notebooks](http://www.epa.gov/Compliance/resources/publications/assistance/sectors/notebooks) .

Contaminants may be also considered according to a chemical classification, more convenient for analysis and monitoring programmes. The main classes are:

- inorganic (or mineral), including base chemicals, metals, salts and mineral fertilisers,
- industrial organic, including most artificial base chemicals for the industry, and specialty compounds,
- agriculture-related organic compounds, including herbicides and pesticides under the name "plant protection products",
- biochemical and bacteriological contaminants.

Table 4: Types of contaminants released to wastewater by industrial activities

<b>Mineral</b>	<b>Organic, industrial</b>	<b>Organic, industrial</b>	<b>Phytosanitary</b>
antimony and compounds	acenaphthene	haloethers	aldrin/dieldrin
arsenic and compounds	acrolein	halomethanes	chlordane
asbestos	acrylonitrile	hexachlorobutadiene	DDT and metabolites
beryllium and compounds	benzene	hexachlorocyclopentadiene	endosulfan and metabolites
cadmium and compounds	benzidine	hexachlorocyclohexane	endrin and metabolites
chromium and compounds	carbon tetrachloride	naphthalene	heptachlor and metabolites
copper and compounds	chlorinated benzene	nitrobenzene	isophorone
cyanides	chlorinated ethanes	nitrophenols	
lead and compounds	chloralkyl ethers	nitrosamines	
mercury and compounds	chlorinated phenols	pentachlorophenol	
nickel and compounds	chloroform	phenol	
selenium and compounds	2-chlorophenol	phthalate esters	
silver and compounds	dichlorobenzenes	polychlorinated biphenyls (PCBs)	
thallium and compounds	dichlorobenzidine	polynuclear aromatic hydrocarbons	
zinc and compounds	dichloroethylenes	2,3,7,8,-tetrachlorodibenzo-p-dioxin (TCDD)	
	2, 4-dimethylphenol	tetrachloroethylene	
	dinitrotoluene	toluene	
	diphenylhydrazine	toxaphene	
	ethylbenzene	trichloroethylene	
	fluoranthene	vinyl chloride	

## 1.4 The particular problems caused by nutrients (N, P)

Excessive amounts of nitrogen and phosphorus in streams leads to the proliferation of algae that reduce available light and, more important, consume oxygen in the water. This phenomenon, known as eutrophication, is caused by pollution from urban wastewater (detergents, excrement), certain types of industrial effluent (fertiliser production, food and beverages, blast furnaces) and runoff containing excess fertiliser from fields.

**Eutrophication:** Excessive enrichment of waters with nutrients, and the associated adverse biological effects (EEA, 1994, *European rivers and lakes*. EEA Environmental Monographs 1).  
"River and lake eutrophication (including adverse biological effects such as heavy algal blooms, oxygen deficiency, fish-kills) caused by excess phosphorus and nitrogen from agriculture, domestic and industrial effluents is a pan-European problem of major concern. The domestic sector and industry are the main contributors of phosphorus, agriculture is the main contributor of nitrogen. Nutrient concentrations in rivers and lakes are highest in a belt from the southern UK, to the Balkans and Ukraine with high population density and/or intensive agriculture. However, due to improved sewage treatment and substitution of phosphorus in detergents, contamination of large rivers with organic matter, ammonia and phosphorus has generally decreased over the last 10 to 15 years except for Eastern Europe. Nitrate concentrations on the other hand continue to increase in most rivers".

## 1.5 Wastewater Processing and Monitoring

Wastewater cannot be released to the environment unless it is demonstrated that it contains no potentially harmful substance at a hazardous level, or that it is first processed to keep all potentially harmful substances below hazardous levels.

Processing wastewater is the standard good practice under the terms of the European Directive (91/271/EEC), and this document precises the level, expressed in Population Equivalent (P.E.) above which processing wastewater is mandatory:

" Member States shall ensure that all agglomerations are provided with collecting systems for urban waste water, at the latest by 31 December 2000 for those with a population equivalent (p.e.) of more than 15 000, and at the latest by 31 December 2005 for those with a p.e. of between 2 000 and 15 000. For urban waste water discharging into receiving waters which are considered 'sensitive areas' as defined under Article 5, Member States shall ensure that collection systems are provided at the latest by 31 December 1998 for agglomerations of more than 10 000 p.e."

When discussing about the urban wastewater processing:

- **'primary treatment'** means treatment of urban waste water by a physical and/or chemical process involving settlement of suspended solids, or other processes in which the BOD5 of the incoming waste water is reduced by at least 20 % before discharge and the total suspended solids of the incoming waste water are reduced by at least 50 %;
- **'secondary treatment'** means treatment of urban waste water by a process generally involving biological treatment with a secondary settlement or other process in which the requirements established in Table 1 of Annex I are respected.
- **'appropriate treatment'** means treatment of urban waste water by any process and/or disposal system which after discharge allows the receiving waters to meet the relevant quality objectives and the relevant provisions of this and other Community Directives;
- **'Sludge'** means residual sludge, whether treated or untreated, from urban waste water treatment plants. Sludge arising from waste water treatment shall be re-used whenever appropriate. Disposal routes shall minimize the adverse effects on the environment.

When discussing about the industrial wastewater processing:

- **'Appropriate treatment'** is applicable to waste water with the same objectives as for urban water, but often by specific methods;
- **'Residual sludge'** is often a hazardous waste, requiring specific management.

**Wastewater monitoring** comprises all the measurements carried out in this perspective analysing potentially harmful substances but also their tracers or metabolites. The substances to be monitored are generally a function of the type of activity generating wastewater (urban water, type of industry, waste pile runoff).

The Directive 91/271/EEC establishes also constraints on the monitoring scheme to be applied to any wastewater discharge or wastewater processing facility:

"Competent authorities or appropriate bodies shall monitor:

- discharges from urban waste water treatment plants to verify compliance with the requirements of Annex I.B in accordance with the control procedures laid down in Annex I.D,
- amounts and composition of sludges disposed of to surface waters.

Competent authorities or appropriate bodies shall monitor waters subject to discharges from urban waste water treatment plants and direct discharges as described in Article 13 in cases where it can be expected that the receiving environment will be significantly affected.

In the case of a discharge subject to the provisions of Article 6 and in the case of disposal of sludge to surface waters, Member States shall monitor and carry out any other relevant studies to verify that the discharge or disposal does not adversely affect the environment".

Reference methods for monitoring and evaluation of results have been described in Directive 91/271/EEC, Annex I, as follows:

"Member States shall ensure that a monitoring method is applied which corresponds at least with the level of requirements described below."

"Flow-proportional or time-based 24-hour samples shall be collected at the same well-defined point in the outlet and if necessary in the inlet of the treatment plant in order to monitor compliance with the requirements for discharged waste water laid down in this Directive. Good international laboratory practices aiming at minimizing the degradation of samples between collection and analysis shall be applied"

"The minimum annual number of samples shall be determined according to the size of the treatment plant and be collected at regular intervals during the year"

## **2 Reference documents, norms and standards**

### **2.1 Wastewater Management requirements by EU**

Wastewater management issues are generally a part of the water policy of the country. In Europe, they are followed under the Water Framework Directive, and accompanied by specific directives.

- Water Framework Directive 2000/60/EC
- Urban Waste-water Treatment Directive 91/271/EEC
- Commission directive 98/15/EC of 27.02.98 amending the Urban Waste-water Treatment Directive 91/271/EEC
- Reports on the Implementation of Council Directive (1999, 2002, 2004)
- Insights on the criteria for identification of sensitive areas (EU Directive 91/271/EEC)

«The Urban Waste-water Treatment Directive is one of the cornerstones of Community water policy and its aim is to protect the environment from the adverse effects of urban waste water discharges ».

By 31.12.2000, waste water treatment facilities should be provided for all agglomerations with a population equivalent above 15 000, which discharged their effluent into "normal areas"

European countries regulations are now transpositions of these EU directives.

## 2.2 Sampling programmes and methods required by EU

They are outlined in Directive 91/271/EEC, Annex I, Reference methods for monitoring and evaluation of results:

"Flow-proportional or time-based 24-hour samples shall be collected at the same well-defined point in the outlet and if necessary in the inlet of the treatment plant in order to monitor compliance with the requirements for discharged waste water laid down in this Directive. "

This requirement does not mention explicitly any norm. However, the European standard for quality procedures being ISO, the most straightforward approach is to follow:

- ✓ ISO 5667-1:1980 Water quality -- Sampling -- Part 1: Guidance on the design of sampling programmes,
- ✓ ISO 5667-2:1991 Water quality -- Sampling -- Part 2: Guidance on sampling techniques ISO 5667-10:1992 Water quality -- Sampling -- Part 10: Guidance on sampling of waste waters.
- ✓ ISO 5667-13:1997 Water quality -- Sampling -- Part 13: Guidance on sampling of sludges from sewage and water- treatment works.

The reference to flow-proportional sampling, further developed in 5667-10, implies that flow measurement is to be carried out using one of the methods mentioned in § 2.3. Reference methods for flow measurement are examined further.

Good international laboratory practices aiming at minimizing the degradation of samples between collection and analysis shall be applied.

This requirement does not mention explicitly any norm. The most straightforward approach is to follow ISO 5667-3:1994 Water quality -- Sampling -- Part 3: Guidance on the preservation and handling of samples. Though no mention is given on requirements on analysis methods, it is advisable to consider the ISO norms on sample preparation and analysis for the monitored substances.

"The minimum annual number of samples shall be determined according to the size of the treatment plant and be collected at regular intervals during the year:

- ✓ 2 000 to 9 999 p. e.: 12 samples during the first year;
- ✓ four samples in subsequent years, if it can be shown that the water during the first year complies with the provisions of the Directive; if one sample of the four fails, 12 samples must be taken in the year that follows.
- ✓ 10 000 to 49 999 p. e.: 12 samples.
- ✓ 50 000 p. e. or over: 24 samples.

This requirement on the number of samples allows to size the programme.

The treated waste water shall be assumed to conform to the relevant parameters if, for each relevant parameter considered individually, samples of the water show that it complies with the relevant parametric value in the following way:

- a) for the parameters specified in Table 1 and Article 2 (7), a maximum number of samples which are allowed to fail the requirements, expressed in concentrations and/or percentage reductions in Table 1 and Article 2 (7), is specified in Table 3;
- b) for the parameters of Table 1 expressed in concentrations, the failing samples taken under normal operating conditions must not deviate from the parametric values by more than 100

- %. For the parametric values in concentration relating to total suspended solids deviations of up to 150 % may be accepted;
- c) for those parameters specified in Table 2 the annual mean of the samples for each parameter shall conform to the relevant parametric values.

Extreme values for the water quality in question shall not be taken into consideration when they are the result of unusual situations such as those due to heavy rain.

These requirements provide guidelines for the interpretation of results. Though no mention is given on requirements on quality insurance, it is advisable to follow ISO 5667-14:1998 Water quality -- Sampling -- Part 14: Guidance on quality assurance of environmental water sampling and handling.

## 2.3 Flow measurement methods by ISO

The set of ISO norms on flow measurement is to be considered, given the variety of field situations in wastewater monitoring:

### Flow measurement – general

- ✓ ISO/TR 5168:1998 Measurement of fluid flow -- Evaluation of uncertainties
- ✓ Assessment of uncertainty in calibration and use of flow measurement devices -- ISO/TR 7066-1:1997 Part 1: Linear calibration relationships
- ✓ ISO 7066-2:1988 Part 2: Non-linear calibration relationships

### Measurement of fluid flow in closed conduits

- ✓ Vocabulary and symbols: ISO 4006:1991
- ✓ Weighing method: ISO 4185:1980
- ✓ Method by collection of the liquid in a volumetric tank: ISO 8316:1987
- ✓ Velocity area method using Pitot static tubes: ISO 3966:1977
- ✓ Coriolis meters (Revision of ISO 10790:1994): ISO/DIS 10790
- ✓ Flowrate measurement by means of vortex shedding flowmeters inserted in circular cross-section conduits running full: ISO/TR 12764:1997
- ✓ Flow rate measurement by means of ultrasonic flowmeters: ISO/DTR 12765
- ✓ Measurement of fluid flow by means of pressure differential devices -- Part 1: Orifice plates, nozzles and Venturi tubes inserted in circular cross-section conduits running full: ISO 5167-1:1991

### Measurement of fluid flow in open channels

#### General aspects:

- ✓ ISO/TR 8363:1997 Measurement of liquid flow in open channels -- General guidelines for selection of method
- ✓ ISO 8368:1999 Hydrometric determinations -- Flow measurements in open channels using structures -- Guidelines for selection of structure
- ✓ ISO 9123:2001 Stage-fall-discharge relationships
- ✓ ISO 9825:1994 Field measurement of discharge in large rivers and floods
- ✓ ISO/TR 9210:1992 Measurement in meandering rivers and in streams with unstable boundaries
- ✓ ISO 2425:1999 Measurement of liquid flow in open channels under tidal conditions

- ✓ ISO 9196:1992 Flow measurements under ice conditions - ISO/TR 11328:1994 Equipment for the measurement of discharge under ice conditions
- ✓ ISO/TR 9209:1989 Determination of the wetline correction

### **Site equipment**

- ✓ ISO 1100-1:1996 Establishment and operation of a gauging station
- ✓ ISO 1100-2:1998 Determination of the stage-discharge relation
- ✓ Weirs
  - ISO 1438-1:1980 Thin-plate weirs - ISO 3846:1989 Rectangular broad-crested weirs - ISO 4360:1984 Triangular profile weirs - ISO 4362:1999 Trapezoidal broad-crested weirs - ISO 4374:1990 Round-nose horizontal broad-crested weirs - ISO 4377:2002 Flat-V weirs - ISO 8333:1985 V-shaped broad-crested weirs - ISO 9827:1994 Streamlined triangular profile weirs
- ✓ Flumes: ISO 4359:1983 Rectangular, trapezoidal and U-shaped flumes - ISO 9826:1992 Parshall and SANIIRI flumes
- ✓ ISO 13550:2002 Use of vertical underflow gates and radial gates
- ✓ ISO 14139:2000 Compound gauging structures
- ✓ ISO 3847:1977 End-depth method for estimation of flow in rectangular channels with a free overfall
- ✓ ISO 4371:1984 End depth method for estimation of flow in non-rectangular channels with a free overfall

### **Open channel methods**

- ✓ ISO 1070:1992 Slope-area method
- ✓ ISO 748:1997 Velocity-area methods
- ✓ ISO 1088:1985 Velocity-area methods -- Collection and processing of data for determination of errors in measurement
- ✓ ISO/TR 7178:1983 Velocity-area methods -- Investigation of total error
- ✓ ISO/TR 9823:1990 Velocity-area method using a restricted number of verticals
- ✓ ISO 4369:1979 Moving-boat method
- ✓ ISO 6420:1984 Position fixing equipment for hydrometric boats
- ✓ Tracer methods: ISO 9555-1:1994 Tracer dilution methods for the measurement of steady flow -- Part 1: General - ISO 9555-2:1992 -- Part 2: Radioactive tracers - ISO 9555-3:1992 - Part 3: Chemical tracers - ISO 9555-4:1992 -- Part 4: Fluorescent tracers -- ISO/TR 11656:1993 Mixing length of a tracer

### **Flow in open channels: devices**

- ✓ ISO 4373:1995 Water-level measuring devices
- ✓ ISO 2537:1988 Rotating element current-meters
- ✓ ISO 3455:1976 Calibration of rotating-element current-meters in straight open tanks
- ✓ ISO 3454:1983 Direct depth sounding and suspension equipment
- ✓ ISO/TR 11974:1997 Electromagnetic current meters
- ✓ ISO/TS 15769:2000 Guidelines for the application of Doppler-based flow measurements
- ✓ ISO 11655:1995 Method of specifying performance of hydrometric equipment

The selection of the method and the appropriate device can be helped by the general-purpose norms on flow measurement.

## 2.4 Laboratory water quality analysis

The use of laboratory water quality analysis ISO norms is recommended. All ISO norms on water analysis, unless wastewater is specifically out of their scope, and more specifically, those on the substances to be monitored:

- ✓ ISO 5815:1989 Water quality -- Determination of biochemical oxygen demand after 5 days (BOD 5) -- Dilution and seeding method,
- ✓ ISO 6060:1989 Water quality -- Determination of the chemical oxygen demand,
- ✓ ISO 11923:1997 Water quality -- Determination of suspended solids by filtration through glass-fibre filters,
- ✓ ISO 5663:1984 Water quality -- Determination of Kjeldahl nitrogen -- Method after mineralization with selenium,
- ✓ ISO 10048:1991 Water quality -- Determination of nitrogen -- Catalytic digestion after reduction with Devarda's alloy,
- ✓ ISO 11732:1997 Water quality -- Determination of ammonium nitrogen by flow analysis (CFA and FIA) and spectrometric detection,
- ✓ ISO 11905-1:1997 Water quality -- Determination of nitrogen -- Part 1: Method using oxidative digestion with peroxodisulfate
- ✓ ISO/TR 11905-2:1997 Water quality -- Determination of nitrogen -- Part 2: Determination of bound nitrogen, after combustion and oxidation to nitrogen dioxide, chemiluminescence detection,
- ✓ ISO 13395:1996 Water quality -- Determination of nitrite nitrogen and nitrate nitrogen and the sum of both by flow analysis (CFA and FIA) and spectrometric detection
- ✓ ISO/FDIS 6878 Water quality -- Determination of phosphorus -- Ammonium molybdate spectrometric method (Revision of ISO 6878-1:1986),
- ✓ ISO/TR 13530:1997 Water quality -- Guide to analytical quality control for water analysis

### Specific ISO norms on wastewater analysis:

- ✓ ISO 9509:1989 Water quality -- Method for assessing the inhibition of nitrification of activated sludge micro-organisms by chemicals and waste waters
- ✓ ISO 10304-2:1995 Water quality -- Determination of dissolved anions by liquid chromatography of ions -- Part 2: Determination of bromide, chloride, nitrate, nitrite, orthophosphate and sulphate in waste water
- ✓ ISO 07.100.20 group: Microbiology of water

### Onsite water quality measurement

- ✓ ISO 7888:1985 Determination of electrical conductivity
- ✓ Determination of alkalinity: ISO 9963-1:1994 Part 1: Determination of total and composite alkalinity -- ISO 9963-2:1994 Part 2: Determination of carbonate alkalinity
- ✓ ISO 10523:1994 Determination of pH
- ✓ ISO 10530:1992 Determination of dissolved sulfide -- Photometric method using methylene blue
- ✓ ISO 7027:1999 Determination of turbidity
- ✓ ISO 5814:1990 Determination of dissolved oxygen -- Electrochemical probe method

## 2.5 Other applicable norms

When no ISO norm is available, or if the available ISO norm is not technically applicable, it is legitimate to use other widely accepted norms and standards. Sources of such standards may be national normative organisations from Europe (DIN from Germany, AFNOR from France, BSI from UK) or outside Europe:

- ✓ ASTM D6538-00 Standard Guide for Sampling Wastewater With Automatic Samplers: Selection and use of automatic wastewater samplers including procedure for their use in obtaining representative samples and the unattended collection of samples representative of the parameters of interest in wastewater, process streams and natural water bodies.
- ✓ US-EPA 600/2-80-018 - January 1980 (NTIS / PB80-135353) Samplers and Sampling Procedures for Hazardous Waste Streams.
- ✓ US-EPA 600/4-82-029 - September 1982 (NTIS / PB83-124503) Handbook of Sampling and Sample Preservation of Water and Wastewater.
- ✓ APHA: CLESCERI L.S., GREENBERG A.E., TRUSSELL R.R. (1989). Standard methods for examination of water and wastewater. 17th edition, APHA, AWWA, WPCF. Washington.
- ✓ Wastewater-related standards
  - 1010 Introduction
  - 1060 Collection and Preservation of Samples
  - 10750 Nematological Examination
  - 10900 Algae Color Plates
  - 1100 Waste Minimization and Disposal
  - 2350 Oxidant Demand/ Requirement
  - 2530 Floatables
  - 3120 Metals by Plasma Emission Spectroscopy
  - 3125 Metals by Inductively Coupled Plasma/Mass Spectrometry
  - 3500-Cr Chromium
  - 4500-N Nitrogen
  - 4500-NH<sub>3</sub> Nitrogen (Ammonia)
  - 5310 Total Organic Carbon (TOC)
  - 5530 Phenols
  - 5910 UV-Absorbing Organic Constituents
  - 6200 Volatile Organic Compounds
  - 6420 Phenols
  - 7020 Quality Assurance/Quality Control
  - 9216 Direct Total Microbial Count
  - 9230 Fecal Streptococcus and Enterococcus Groups
  - 9245 Nitrifying Bacteria
  - 9260 Detection of Pathogenic Bacteria.

## 2.6 National Estonian regulations and practice

National Estonian sampling methods regulations are as follows:

- Regulation of the Minister of the Environment on sampling methods 6.05.2002 No 30
- Obligations of Estonia under the Accession Treaty from Estonian government, sources ([http://www.vm.ee/eng/euro/kat\\_308/3454.html#22](http://www.vm.ee/eng/euro/kat_308/3454.html#22)):

Directive 91/271/EEC on urban waste water treatment: a transitional period until 31 December 2010 for the renovation / construction of sewerage systems and waste waters treatment facilities agreed with the following intermediate targets: Collecting systems in line with Article 3 of Directive 91/271/EEC will be provided as from 31 December 2009 in agglomerations of a population equivalent above 10,000 and as of 31 December 2010 in agglomerations of a population equivalent between 2,000 and 10,000. While treatment in line with Article 5 of Directive 91/271/EEC will be provided for the total biodegradable load of

948,840 population equivalent in all agglomerations with a population equivalent of more than 10,000 as from 31 December 2002, treatment in line with this provision will be provided in all agglomerations with a population equivalent above 2,000 as from 31 December 2010.

The following practical rules are extracted from the current Estonian regulation. Most of these rules are compatible with ISO norms and European best practice. The fair operation rules extend beyond ISO norms and European best practice.

### **Criteria for the sampling point:**

- (1) Sample shall be taken from well-mixed straight streams sufficiently far from outlet to the receiving water body to prevent the impact thereof.
- (2) If waste water is discharged by submerged pipe or deep sea outlet, the sample shall be taken from the last embankment well, which is not affected by sea or surface water.
- (3) Sample from the waste water treatment plant shall be taken after the last treatment stage. In case of absence of waste water treatment plant the sample shall be taken from the point of discharge of waste water from the territory of the source of pollution (from nearest sewage well, dike etc).
- (4) Before sampling, the sampling site shall be cleansed and the temporary additive matter must be out flowed.
- (5) In absence of current sections with turbulent flow, the measurement circumstances shall be created at least 24 hours before sampling

### **Rules and criteria on sampling – fair operation:**

- (1) The sampler shall announce the possessor of the source of pollution about the sampling, must give explanations about the sampling and add the written comments of the possessor to the sampling record.
- (2) The sampling points and schedules from public waste water facilities shall be agreed with the possessor of the waste water facilities.
- (3) The waste water sample shall be taken directly into the sampling bottle or by scoop or wide-mouthed bottle, which is mounted to the handle of suitable length.
- (4) When selecting the type of sample, the peculiarities of the formation of the waste water from the pollution source shall be examined. Commonly the 24 hours or for industrial enterprises the working day flow proportional composite sample is taken with automatic sampler.

### **Criteria on wastewater sampling:**

- (5) A spot sample of waste water shows the content of the waste water at a given time, but if there is little variation of flow and concentration in the waste water ( $\pm 10\%$ ), such a result is also representative for a longer period.
- (6) If pollutant content and waste water amount vary, the spot samples shall be taken frequently in order to get representative composite samples. For industrial waste water, it is important that composite samples contain spot samples from peak load.
- (7) In absence of turbulent flow or when the flow is created artificially, spot samples from different points along the current should be taken and considered as composite.
- (8) If the waste water is discharged to the recipient by a pipe which lies higher than the water table, the sample shall be taken directly from the jet, at that avoiding the aeration of the sample.
- (9) In case of several outlets, the samples shall be taken from each outlet and the load shall be summarised.

**Rules on sampling: sample information:**

- (1) The waste water sampling record shall contain the data about discharge measurements.
- (2) For solution of later controversial points, an additional sample can be taken and preserved, if needed. The additional sample shall be sealed on the spot if required by the possessor of the pollution source and maintained as corpus delicti. The sample shall be sealed in a way that it can not be opened without spoiling the seal print.
- (3) The sealing shall be fixed in the sampling record and confirmed by the signature of the sampler and possessor of the pollution source or its legat. If the possessor of the pollution source refuses to sign the protocol, the corresponding remark shall be made in the protocol and confirmed by signatures of two attending witnesses.
- (4) The worker of the testing laboratory receiving the sample shall make a recording into the sampling.

**Discharge measuring:**

Discharge Q is the quantity of fluid passing a certain cross section per unit of time,  $Q(l/s \text{ or } m^3/s) = V(\text{flow speed, m/s}) \times A (\text{cross section of the stream, } m^2)$ .

- The amount of the fluid crossing the measuring flume or overflow is calculated by the height of the water column in the place of overflow or by the depth of water in the measuring flume. During the measuring the water level is recorded and the discharge is determined by the characteristic of the device.
- It is recommended to use stationary measuring devices and to do the measurements in continuous regime. In case of stable conditions the results of discrete measurements can also be used, at that the measuring frequency shall guarantee sufficient measurement accuracy and representative results.
- If in connection of surface or waste water sampling the discharge is measured, the sampler shall include the results of discharge measurements into the surface or waste water sampling record (coordinates and description of the measuring point, date and time, measuring device or method, data about the gauging section, location of gauging verticals and depths, results of measured indicators).

**Recommended devices for flow rate measurement:**

The following standard measuring devices should be used for discharge measurement:

- 1) rotameter: used for flow speed measuring of the fluid with low content of suspended solids (beware ! many rotameters are allergic to dirt !)
- 2) ultrasonic and magnetic-inductive flowmeters; Magnetic-inductive flowmeters are used for flow speed measuring of every kind of fluids, ultrasonic flowmeters are used for flow speed measuring of the clean and slightly polluted fluids.
- 3) differential manometers are used for flow speed measuring of the fluid with low content of suspended solids. For flow speed measurement of fluids with higher content of suspended solids nozzles with special shape are used.
- 4) measuring flume or overflow: used for measuring of surface and waste water discharge. Measuring flumes and overflows shall be installed horizontally and there shall be no bypasses.

In waste water discharge measurement the devices less sensitive to the content of suspended solids shall be preferred.

**Other methods for water flow rate measurement:**

If it is not possible to use standard measuring devices or it is disproportionately costly, the following non-standard measuring methods can be used:

- 1) volumetric method (the time of fulfilment of calibrated container is measured. The discharge is calculated as a quotient of the volume of the container and fulfilment time);
- 2) floater or tracer (the time, which floater or tracer takes to cover a distance of certain length, is measured and an average flow speed is calculated. Discharge is a product of flow speed and stream cross-section);
- 3) streambed and water level gradient (requires exceptional conditions);
- 4) characteristics about the pump or sewage network ( i.e. relation of the volume of pumped fluid from the lifting height and energy consumption, pressure in the network, difference of pressures etc.) for discharge measuring in severe environmental or for technically complicated objects;
- 5) indirect methods (i.e. water use per production unit, served object, working time of the device, regeneration of the device etc.) can be use before application of safer measuring methods, or in parallel with those to get reference data.

Only methods 1) and 2) can be used according to ISO norms and European practice.

### **Criteria on sewage sludge sampling:**

- (1) Sewage sludge samples shall be taken in a way, that the...result will characterise the whole studied amount of sludge. If the sewage sludge is stratified, spot samples with equal size shall be taken from different points and different layers perpendicularly with layers. Those spot samples shall be mixed or composite.
- (2) Composite sewage sludge samples shall consist of at least 5 spot samples. Composite sewage sludge compost samples shall consist of at least 10 spot samples.
- (3) The spot samples of sewage sludge with equal size shall be taken from different points and different layers: a) from liquid sewage sludge at least 1 litre; b) from solid sewage sludge at least 0,5 kg.
- (4) The size of the sewage sludge sample shall be agreed with testing laboratory analysing the sample before sampling
- (5) The period of taking spot samples for composite sample shall not exceed 24 hours.
- (6) To get a composite sample from liquid sewage sludge, the spot samples shall be mixed in a vessel made from inert material and homogenised by shaking.
- (7) In order to get the composite sample, the solid, except with gelic consistence, spot samples of sewage sludge shall be put into conical heap and the matter shall be mixed at least three times in a way, that the matter from lower part of the heap is put on the top of the heap or the special screen box shall be used.
- (8) To get the composite sample, the spot samples of sewage sludge of gelic consistence shall be mixed with a tool made of inert material.
- (9) If there is a need to get two or more composite samples or additional samples from mixed spot samples, the sampling matter shall be mixed again before every composite sample.

### **Compilation of sewage sludge sampling record:**

The sewage sludge sampling record shall in addition to the information presented in section 3 of § 8 contain the following information: 1) the number of compounded spot samples and the location scheme thereof; 2) sewage sludge treatment (treated or untreated sludge, way of treatment); 3) description of the sample (solid, gelic or liquid sludge, colour, smell etc); 4) the age of the sludge compost.

### **Preservation of sewage sludge samples:**

- (1) The sewage sludge samples for determination of the content of dry matter or moisture shall be preserved in airtight containers.

(2) Samples taken from solid sewage sludge can be preserved in twofold water- and dustproof polyethylene bags, except those samples taken for determination of the content of organic matter

### 3 Water Flow and Discharge Measurements

#### 3.1 Theoretical bases on water flow rate measurement

##### Instant vs. cumulative flow measurement:

Instant measurement is recorded and can be associated with instant contaminant concentration or average (Figure 1).

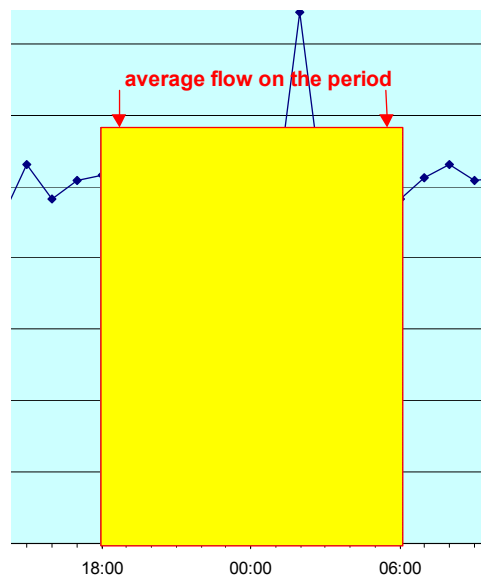
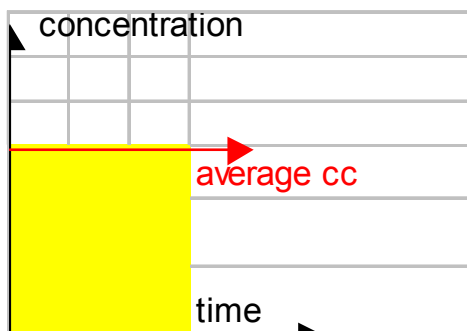

Figure 1: Instant flow and concentration measurement along time and averages

Cumulative flow measurement can be associated with average contaminant concentration only (Figure 2).



$$Poll = I_t (d(flow) \times d(conc))$$

Figure 2: Concentration-time relationships for cumulative flow measurement

### Gauging station, limnigram, hydrogram

Flow, for a watercourse, is measured at a place where it is regular and representative of it. Knowing the characteristics of the place, a relationship is established between H (water level) and flow. The limnigram is the record of water level along time (Figure 3).

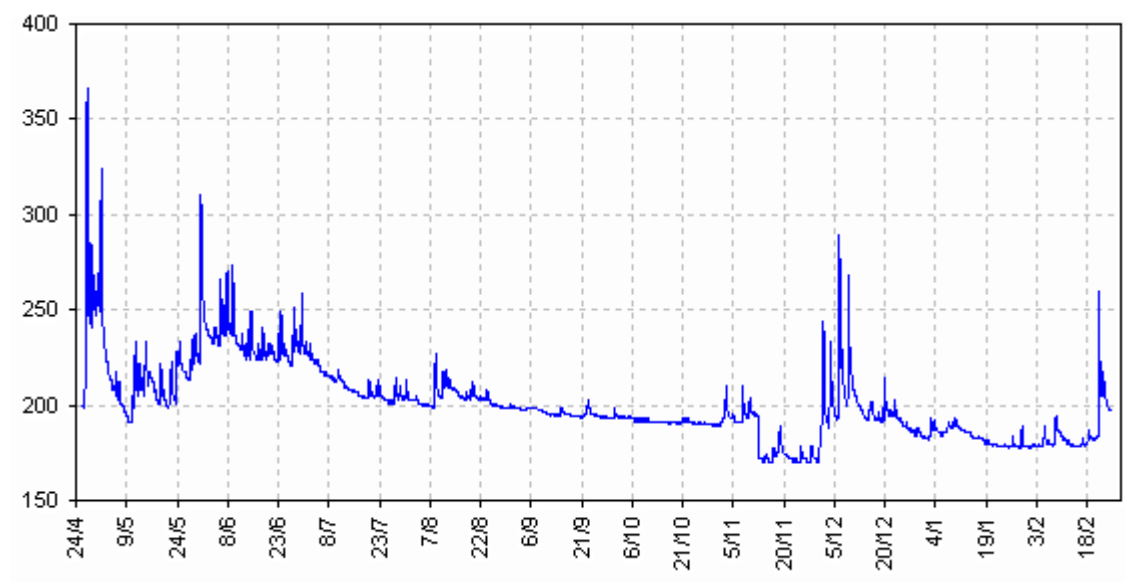

Figure 3: Example of limnigram - time as X, water height as Y

If the relation is bi-univocal, the relationship is used for gauging station calibration (Figure 4).

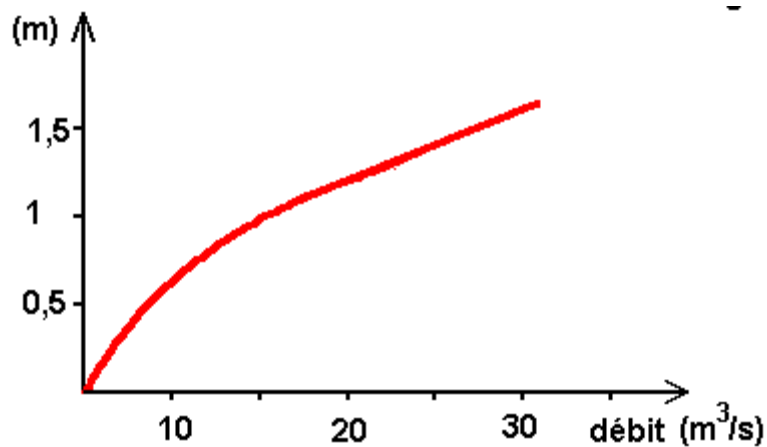

Figure 4: Example of calibration curve - flow as X, water height as Y

The calculated flow record is an hydrogram.

Calibration can be done by volumetric, overflow, flume, tracer, ultrasonic, differential piezometric or magnetic-inductive methods. Routine measurement is by level or floater methods.

A gauging station is often the best suitable location for on-site pollution measurement or sample collection. However, sampling should not be done close to a weir.

## Homogeneity of flow vs. channel section

Water flow must be known precisely if the pollutant transfer is to be evaluated. Measurement must take into account the inhomogeneity of the flow. Flow speed is most frequently higher in the middle of the channel. Flow must never be measured from course side.

## 3.2 Methods for water flow rate measurement

### Cumulative methods

Volumetric (filling a container), Figure 5.

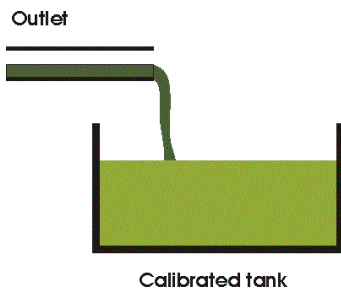

Figure 5: Volumetric flow rate measurement

Overflow (through a normalised outlet), Figure 6.

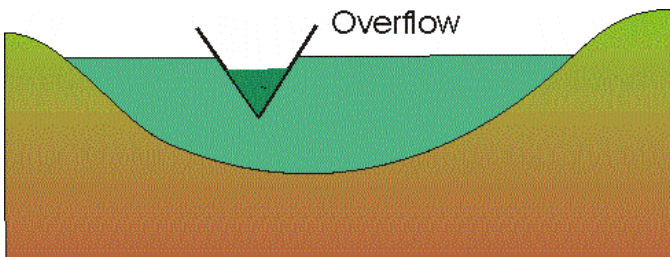

Figure 6: Overflow method flow rate measurement

Cumulative methods can be applied after site calibration and allow cumulative sampling

### Instant methods

- Floater (with boat)
- Tracer and dilution

Rotameter (flow speed measuring devices)

Differential manometers

Ultrasound & Doppler devices

Instant methods could be applied anywhere but calibration has to be done in any case.

## 4 The sampling Site

### 4.1 Design of the sampling programme

Useful elements can be found in ISO 5667-10:1992 Water quality -- Sampling -- Part 10: Guidance on sampling of waste waters.

#### Objectives of a sampling program

- Suitability of a water resource for public use
- Evaluation of the effect of a wastewater discharge
- Evaluation of the performance of wastewater treatment

#### Sampling situations

- Evaluation of the variability of the monitored water
- Preliminary sampling and reconnaissance analysis
- Safety considerations on sampling situations
- Selection of sampling locations - monitoring network
- Natural and meteorological constraints
- Flow measurement
- Composition and homogeneity of the water

Careful identification of the key constraints on the programme.

### 4.2 Types of wastewater sampling site

1) plant runoff or sewage outlet (pipe)

- automatic sampling and flow measurement recommended
- otherwise, sampling and discharge data from a collection tank

2) plant runoff or sewage outlet (open channel)

- automatic sampling and flow measurement recommended
- pumping samples from a floating pipe above the channel bottom

3) river, downstream of the outlet (Figure 7)

- sampling site near a gauging station, in the zone of fast flow
- avoid sampling close to weirs (sedimentation, accumulation)
- sufficiently downstream to allow complete mixing of input wastewater
- pumping samples from a floating pipe above the channel bottom

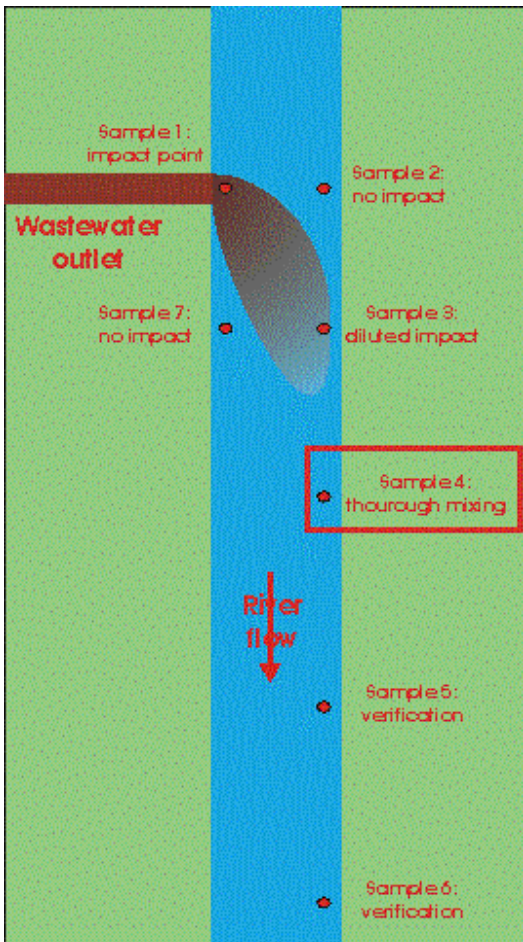

Figure 7: Mixing downstream a wastewater outlet

- 4) surface water body (lake, pond) receiving waste water
- preliminary investigations for variations with depth
  - pumping samples from a tube or a pipe at various depths

- 5) groundwater affected by waste water infiltration
- preliminary investigations for variations with depth
  - samples are to be collected by usual groundwater sampling methods at various depths in the well

### 4.3 Constraints on waste water sampling sites

- 1) From a collection tank
- ensure full homogenisation of the tank before sampling
  - sampling is easier with a disposable vertical sampler
  - discharge data are to be collected at the time of sampling

- 2&3) Open channels and rivers (flowing water)
- automatic sampling and flow measurement recommended
  - sampling point in the fastest flow area (channel centre)
  - pumping samples from a floating pipe above the channel bottom (avoid bottom sediments, floating scum and debris)

- 4 & 5) surface water body (lake, pond) and groundwater (static water)

Density of contaminants must be taken into account:

Samples should be collected from various depths. This would allow to collect:

- soluble contaminants from mid-depth sample; plus, if any:
- low density contaminants (LNAPL) from near-surface sample
- high density contaminants (DNAPL) from near-bottom sample

This can be achieved by pumping samples from a pipe at various depths, or sampling with a disposable vertical sampler.

## 5 Sampling Methods

### 5.1 Types of wastewater samples

Spot sample (discrete, snap, grab, random)

A spot sample provides information only on the instant value of pollution. It is the only type of sample which can represent a pollution peak such as an accidental discharge.

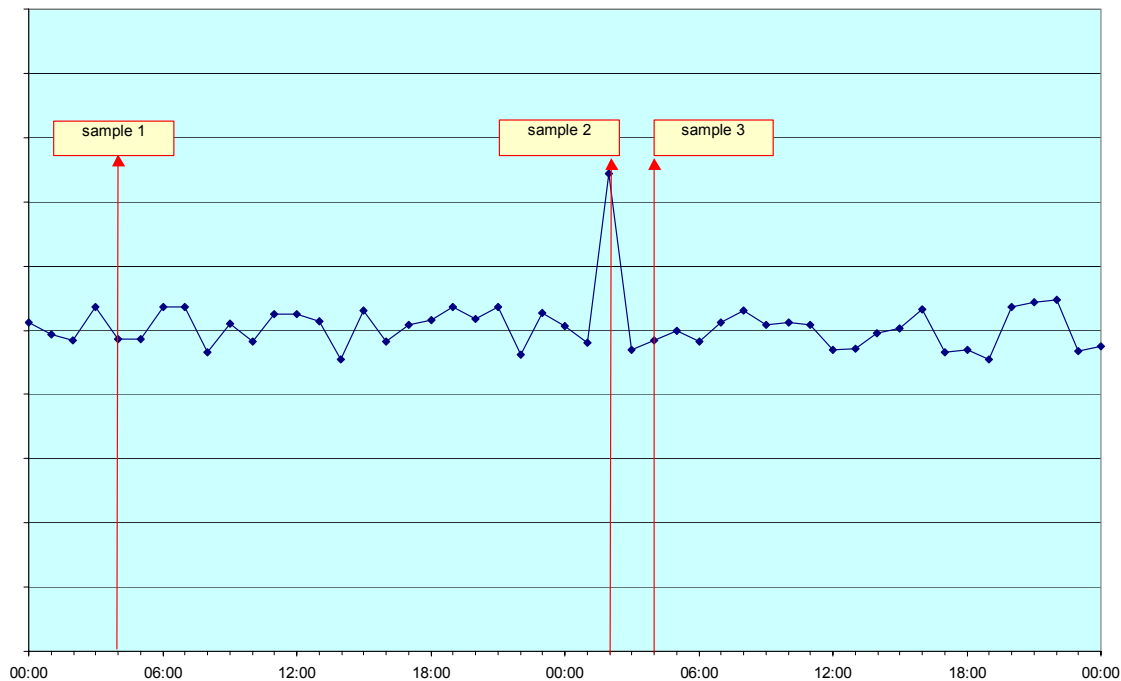

Figure 8: Spot samples of a variable source (time as X-axis, flow as Y-axis)

“Grab samples are individual samples collected over a period of time not exceeding 15 min and are representative of conditions at the time of sampling (ASTM, US-EPA)”

Grab samples are appropriate when samples are needed to:

- Characterise an effluent that is not continuous,
- Provide information about instantaneous concentrations of pollutants,
- Allow collection of samples of varied volume,
- Corroborate composite samples,

- e) Monitor parameters not amenable to compositing (for example, pH, temperature, dissolved oxygen, chlorine, purgeable organics (unless a specialised sampler is used), oil and grease and others specified by a permit which may include phenols, sulfites and hexavalent chromium).
- f) Characterise a waste stream in detail where rapid fluctuations of parameters occur (sequential grabs);
- g) Obtain time-weighted composite samples

Time-weighted composite sample

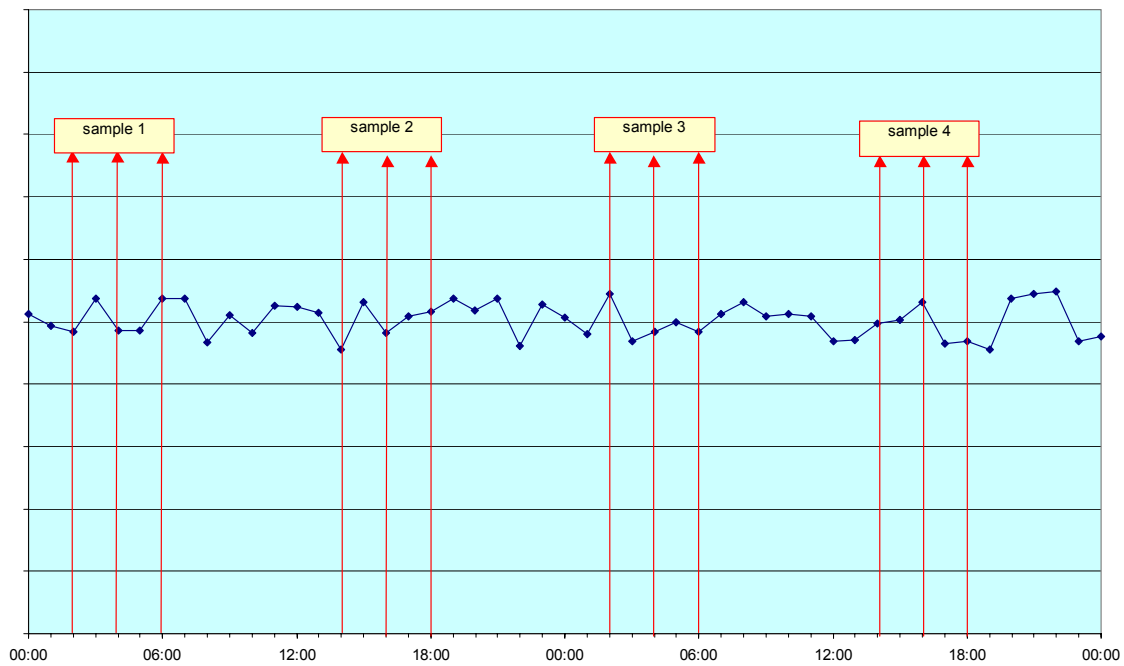

Figure 9: Time-weighted composite samples of a variable source

## Flow proportional composite sample

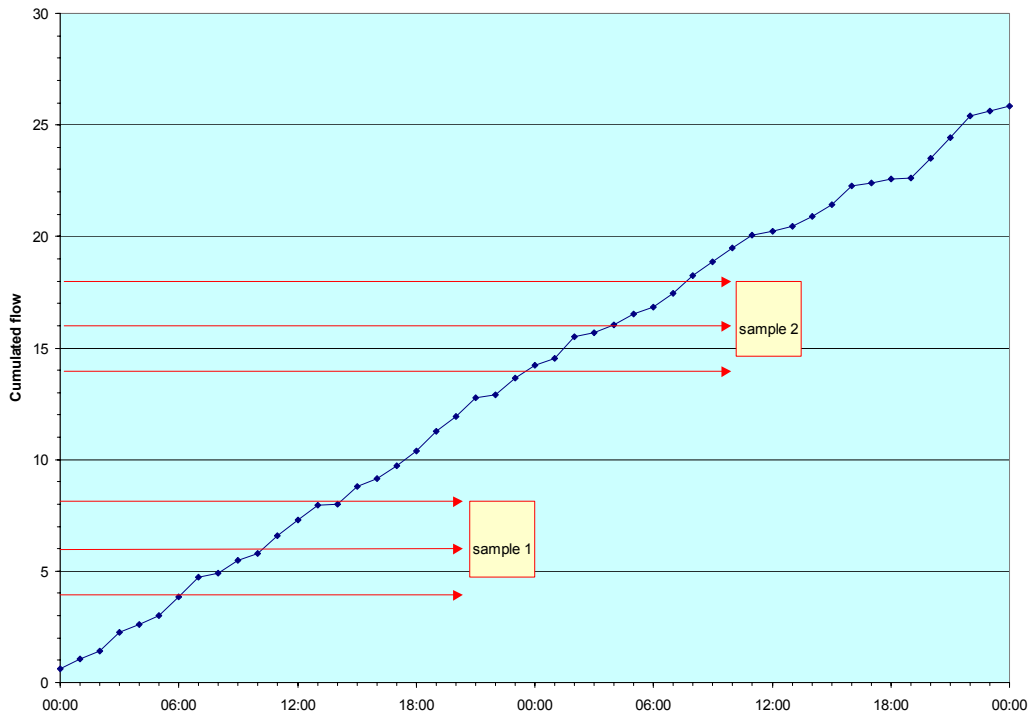

Figure 10: Flow proportional composite samples (cumulate flow as Y-axis)

## Continuous sampling

This type of sampling is obtained by pumping a small volume of water along a given period of time, integrating thus chemical variations. It may be done at:

- Fixed flow rate
- Variable flow rate

## Series sampling

- Depth series are lots of samples from various depths at the same location:
- Profile series are lots of samples taken in sequence at the same location, for instance across a water course or big open channel:

## Large volume sampling

Specific techniques are applied when the planned analyses require large volumes. Specific equipment is often necessary to ensure the representativity of such samples.

## 5.2 Criteria for sampling

### Procedures and special cautions

- General rules on sampling equipment
- Equipment should be non-contaminating
- Equipment should be non-absorbent
- Equipment should be easy to clean

Types of sampling containers

Glass, PVC, PTFE,

Water samplers

Bucket,

Weighted bottle

Sampling cylinder

Bottom sampler

Pumping samplers

## Standard water sampling methods

## 6 On-site operations

### 6.1 On-site measurements

Some parameters cannot be measured in the laboratory, because they evolve quickly after sampling and during transportation:

- pH
- Eh (redox potential, ORP)
- Electrical conductivity (EC)
- Dissolved Oxygen (DO)
- Temperature
- Alkalinity

These parameters must thus be measured on site, at the sampling point or in the collection container. Remember that calibration and sensor care are essential!

### 6.2 On-site contaminant measurement

Most contaminants cannot be measured by on-site methods as reliably as in the laboratory. However, on-site methods can be used to assist sample selection, for instance through identifying points with higher concentration.

#### Test kits

Reagent colour tests were developed by MERCK and other manufacturers for many metals and other contaminants

#### Chromatography

The following techniques can be used on site:

- gas chromatography for organics
- GC/MS mobile analysers (gas chromatograph coupled with a mass spectrometer)

### 6.3 On-site sample preparation

#### Sample homogenisation

- After collection from the sampling vessel (one or several runs), the sample must be thoroughly mixed before extraction of bottles for the laboratory

### Sample splitting

- Several bottles often need to be provided to the laboratory for the realisation of all the analyses
- Some analyses require specific conditioning of the sample on site, or within 24 hours of sampling
- All the bottles must be taken from the same homogenised sample.

### Sample filtration

- Scum and heavy particle removal
- To avoid excess scum and heavy particles, samples should not be taken too close from surface or bottom
- Protect the inlet of the sampling tube
- Splitting of the sample for various analyses
- On-site or near-site filtration (to 0.45 µm) should be carried out for bottles dedicated for certain analyses
- on-site: cartridge filters and syringes
- near site (within 24 hours): Filter paper on funnel, or
- “Coffee-pot” filtration unit with Nalgene filters

However, for wastewater, it is often desirable to analyse unfiltered samples.

### Sample identification

- Without a 100% reliability of this step, no environmental result is worth consideration! Any short-cut on identification will result in uselessness of any further efforts...

Part of the quality of the analyses depend upon careful field preparation

### Sample conditioning for analysis

#### Sample evolution

The following causes may explain evolution of the sample chemical composition between the site and the analysis process:

- Algae, bacteria
- DO oxidation
- Precipitation

#### Sample preservation

The following precautions are required:

- Filling the bottles up to the neck!
- Selecting the bottle material and cleaning agent
- Sterilisation of bottles
- Temperature and light control
- Filtration: for the right analyses
- Preservative reagents, to be added in specific bottles for specific analyses

## Sample conditioning for analysis

Table 5: Sample conditioning on site before analysis

Substance to be analysed	Reagent	Condition
Major cations (Ca, Mg, Na, K) and metallic trace elements	HNO <sub>3</sub> pH < 2	pH < 2
Total Hg	1 % K <sub>2</sub> Cr <sub>2</sub> O <sub>7</sub> -5 g/l & HNO <sub>3</sub>	pH < 2
Dissolved Hg	1 % K <sub>2</sub> Cr <sub>2</sub> O <sub>7</sub> -5 g/l & HNO <sub>3</sub>	pH < 2
Total organic carbon (TOC)	H <sub>2</sub> SO <sub>4</sub> pH < 2	pH < 2
Dissolved organic carbon (DOC)	H <sub>2</sub> SO <sub>4</sub> pH < 2	pH < 2
COD - P total - Kjeldahl nitrogen	H <sub>2</sub> SO <sub>4</sub> pH < 2	pH < 2
Oxidability	H <sub>2</sub> SO <sub>4</sub> pH < 2	pH < 2
Total Hydrocarbon	H <sub>2</sub> SO <sub>4</sub> pH < 2	pH < 2
Phenol (index)	CuSO <sub>4</sub> (250 mg) + H <sub>3</sub> PO <sub>4</sub>	pH < 4
AOX	HNO <sub>3</sub> pH < 2 + Na Sulfite	pH < 2
Total or free Cyanide	NaOH	pH > 10
Sulphide S=	Na OH + 1 ml Zn acetate solution 220 g/l	pH > 10
Endosulfan	H <sub>2</sub> SO <sub>4</sub>	pH < 2
Organo phosphorus Pesticides	HCl 0.1N or NaOH 0.1N	3.5 < pH < 4.5

In order to avoid modification of the sample between site and lab, some reagents must be added.

## 6.4 Introduction on wastewater analyses

### Specificity of wastewater chemistry

- Most water analysis methods are based on low-concentration potable water. They are applicable to saline water only with adaptations.
- Wastewater may be highly saline and/or rich in organic matter.
- Dilution can reduce salinity but lowers detection limits.
- Mineralization and filtration techniques must be more carefully applied for adequate removal of organic matter.

### Cross-contamination in the laboratory

- High concentration in contaminant substances (metals, organics) may affect lab equipment and increase background noise in drinking water samples.
- It is important to ensure separation of wastewater samples from drinking water samples in the laboratory schedule.

### Continuous monitoring of wastewater emission

- Continuous monitoring of wastewater emission comprises continuous measurement of wastewater discharge and of some key parameters (pH, EC...).
- It requires the installation of equipment for permanent measurement and automatic sampling.
- Automatic sampling is done at regular intervals (by time or volume) and may be also triggered by sudden variations of water flow or of key parameters.

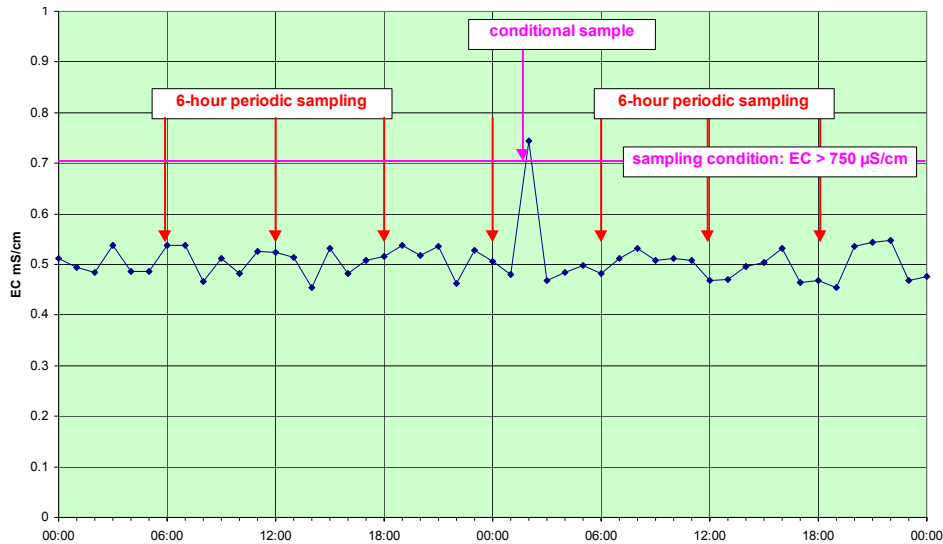

Figure 11: Conditional sampling in response to parameter variations

Dedicated equipment is marketed by several manufacturers (ISCO, American Sigma...) under the name "autosampler". The most efficient units are those with parameter measurement and recording capabilities, allowing the instrument to record together the sampling history, flow variations and parameter (pH, EC...) variations. Conditional sampling (spot samples triggered by sudden variations of water flow or of key parameters) can be done only by such instruments.

If a relationship between contaminants and key parameters can be established, it provides an evaluation of total emission:

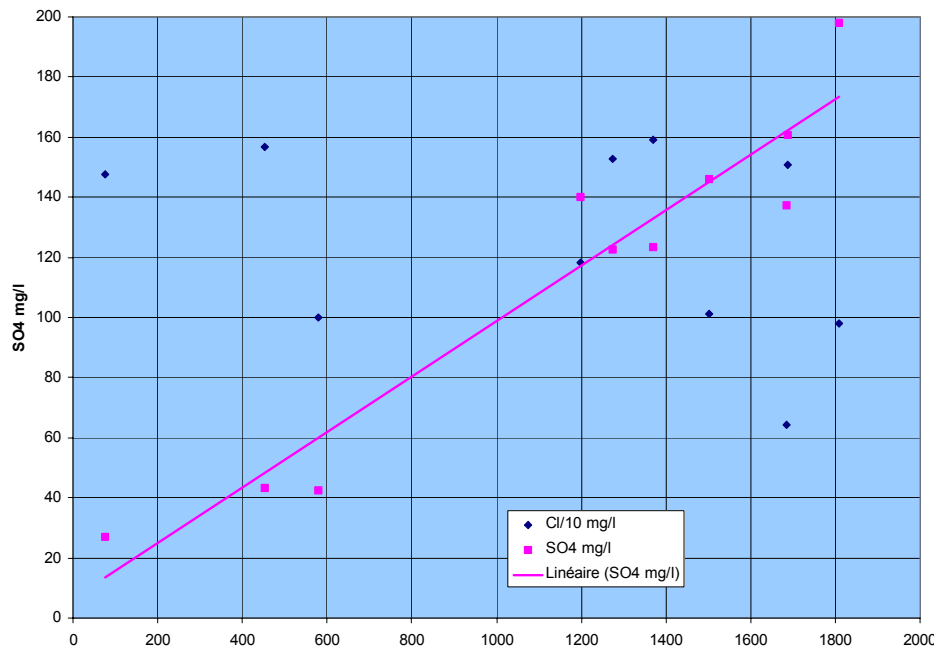

Figure 12: relationship between a contaminant and a parameter that can be continuously monitored (x-axis: EC)

### Continuous monitoring of target water body contamination (exposure monitoring)

- This is achieved by the conjunction of continuous measurement of key parameters and periodic analysis of all potentially present contaminants on a network of representative monitoring stations.

- These analyses are to be done on regular manual spot samples, or automatic spot or composite samples.
- Automatic sampling may be triggered by sudden variations of water flow or of key parameters
- Cumulated exposure can also be assessed by “recording samplers” (based on adsorption sensors).

The purpose of such monitoring is to ensure that the water resource is never dangerously contaminated.

## 7 Pollution flow calculation

### Steady source, steady flow: the ideal case!

In this case, no significant variations are observed in a given period of time:

Pollution flow  $P = \text{Concentration } C \times \text{average flow } F$  (1).

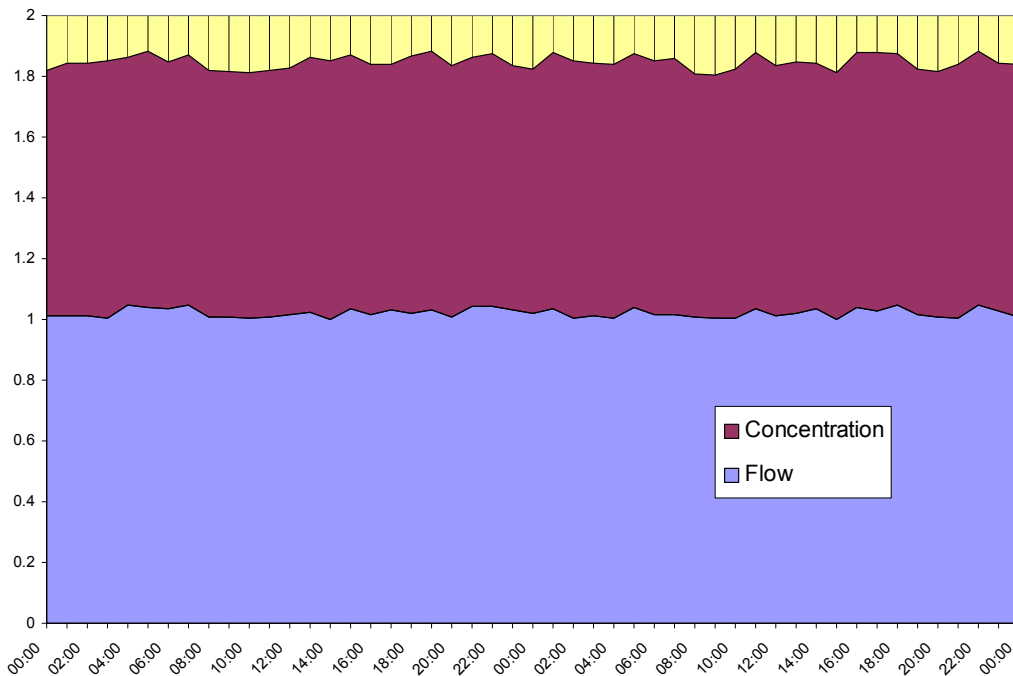

Figure 13. Steady source, steady flow

### Steady source, variable flow:

Flow must be integrated in order to calculate the wastewater volume.

Total pollution = total volume x mean concentration

Pollution flow may be calculated only once concentration is modelled.

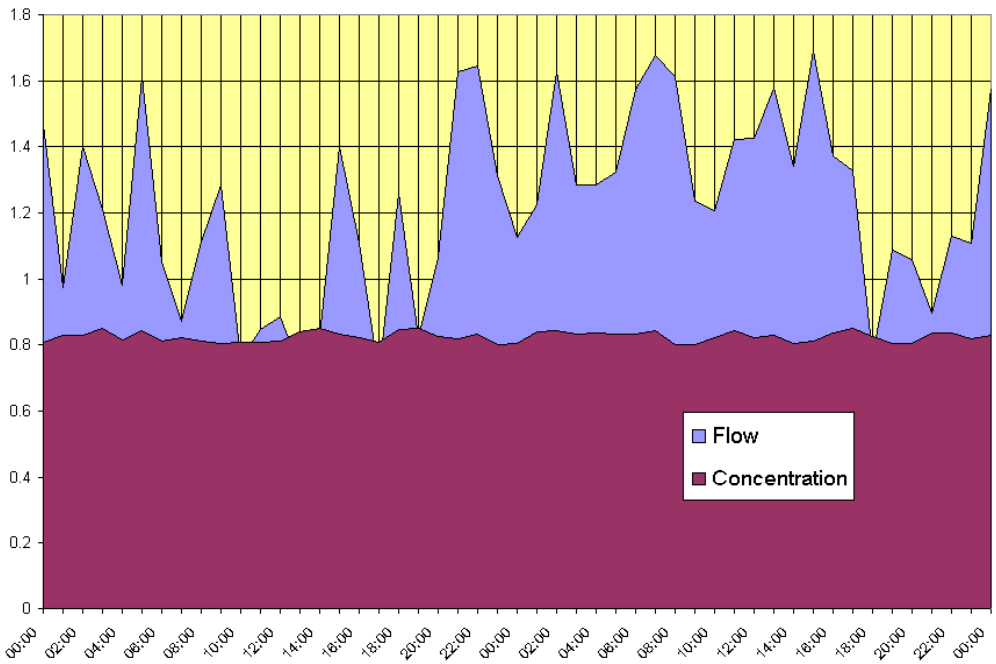

Figure 14. Steady source, variable flow

**Steady flow, variable source:** Concentration must be integrated or interpolated with the help of another parameter that can be continuously monitored.

Total pollution = average flow x time-weighted concentration

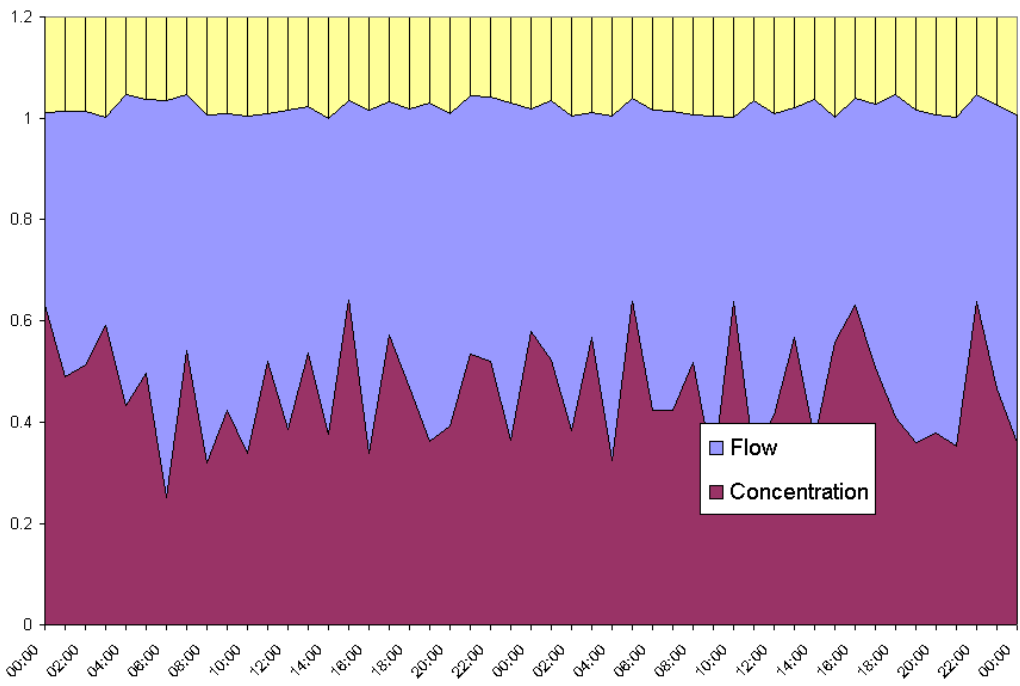

Figure 15. Steady flow, variable source

Pollution flow may be calculated only once concentration is modelled.

**Variable flow and pollutant concentration:**

Concentration must be continuously monitored as well as flow measured. Pollution flow can be assimilated to small increments  $P=C \times F$  when reduced to small time intervals (the « sampling time » of the concentration and flow monitoring devices).

The pollution flow, as a function of time, is the result of the integration of these small increments. Integration may be done graphically or using a chemical model.

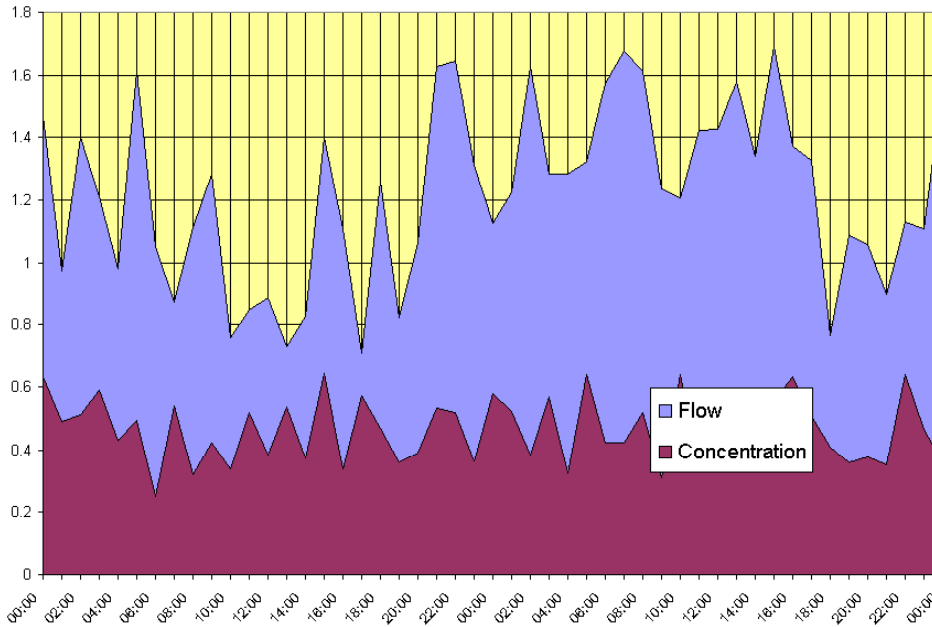

Figure 16. Variable flow and pollutant concentration  
Pollution flow must often be modelled rather than obtained by equation.

## Documentation page

Publisher	Finnish Environment Institute SYKE	Date	August 2005
Author(s)	Ain Lääne and Pertti Heinonen (Editors)		
Title of publication	Sampling. Presentations of three training seminars about Quality Assurance (QA), Biological methods of Water Framework Directive and Waste water sampling techniques		
Parts of publication/ other project publications	The publication is available in the Internet: <a href="http://www.environment.fi/SYKE">http://www.environment.fi/SYKE</a> > Publications > Mimeograph series		
Abstract	Three training seminars about the Quality Assurance in sampling and biological methods of EU Water Framework Directive, and about waste water sampling techniques were organized in Estonia during 2002 and 2004. The Viru-Peipsi CAMP and the Finnish Environment Institute (SYKE) have in co-operation collected and edited the key presentations of the seminars in this proceeding.		
Keywords	Sampling, Quality Assurance, biological methods, monitoring, EU Water Framework Directive, waste water		
Publication series and number	Suomen ympäristökeskuksen moniste 328		
Theme of publication			
Project name and number, if any			
Financier/ commissioner			
Project organization			
	ISSN 4055-0792	ISBN 952-11-2053-3 952-11-2054-1 (pdf)	
	No. of pages 128	Language English	
	Restrictions Public	Price -	
For sale at/ distributor	Finnish Environmet Institute, Customer service E-mail: <a href="mailto:neuvonta.syke@ymparisto.fi">neuvonta.syke@ymparisto.fi</a> tel. +358 9 4030 0190, fax +358 9 4030 0190		
Financier of publication	Finnish Environmet Institute, P.O.Box 140 FIN-00251 Helsinki, Finland		
Printing place and year	Edita Prima Ltd, Helsinki 2005		
Other information			

# Kuvailulehti

Julkaisija	Suomen ympäristökeskus SYKE	Julkaisu-aika Elokuu 2005
Tekijä(t)	Ain Lääne ja Pertti Heinonen (toimittajat)	
Julkaisun nimi	Sampling, Presentations of three training seminars about Quality Assurance (QA), Biological methods of Water Framework Directive and Waste water sampling techniques	
Julkaisun osat/ muut saman projektin tuottamat julkaisut	Julkaisu on saatavissa myös Internetistä: <a href="http://www.environment.fi/SYKE">http://www.environment.fi/SYKE</a> > Publications > Mimeograph series	
Tiivistelmä	Vuoden 2002 ja 2004 aikana järjestettiin Virossa kolme seminaaria, joissa käsiteltiin näytteenoton laadun varmistusta ja EU:n vesipuitedirektiivin biologisia menetelmiä sekä jäteveden näytteenottotekniikka. Viru-Peipsi CAMP ja Suomen ympäristökeskus (SYKE) ovat koonneet tähän julkaisuun seminaarien keskeisimmät esitelmät.	
Asiasanat	Sampling, Quality Assurance, biological methods, monitoring, EU Water Framework Directive, waste water	
Julkaisusarjan nimi ja numero	Suomen ympäristökeskuksen moniste 328	
Julkaisun teema		
Projektihankkeen nimi ja projektinumero		
Rahoittaja/ toimeksiantaja	Suomen ympäristökeskus	
Projektiryhmään kuuluvat organisaatiot		
	ISSN 1455-0792	ISBN 952-11-2053-3 (nid.) 952-11-2054-1 (pdf)
	Sivuja 128	Kieli englanti
	Luottamuksellisuus Julkinen	Hinta -
Julkaisun myynti/ jakaja	Suomen ympäristökeskus, asiakaspalvelu sähköpostiosoite: <a href="mailto:neuvonta.syke@ymparisto.fi">neuvonta.syke@ymparisto.fi</a> puh. (09) 4030 0119, faksi (09) 4030 0190	
Julkaisun kustantaja	Suomen ympäristökeskus	
Painopaikka ja -aika	Edita Prima Oy Helsinki 2005	
Muut tiedot		

# Presentationsblad

Utgivare	Finlands Miljöcentral SYKE	Datum Augusti 2005
Författare	Ain Lääne och Pertti Heinonen (redaktörer)	
Publikationens titel	Sampling. Presentations of three training seminars about Quality Assurance (QA), Biological methods of Water Framework Directive and Waste water sampling techniques	
Publikationens delar/ andra publikationer inom samma projekt	Publikationen finns tillgänglig på Internet: <a href="http://www.environment.fi/SYKE">http://www.environment.fi/SYKE</a> > Publications > Mimeograph series	
Sammandrag	Tre träningsseminarier om kvalitetskontroll och biologiska metoder (förutsatt av EG-vattenramdirektivet) i provtagning samt provtagningsmetoder av avloppsvatten organiserades under åren 2002 och 2004 i Estland. De viktigaste föredrag av dessa seminarier har ny publicerats i samarbete mellan Viru-Peipsi CAMP och Finlands Miljöcentral (SYKE).	
Nyckelord	Sampling, Quality Assurance, biological methods, monitoring, EU Water Framework Directive, waste water	
Publikationsserie och nummer	Suomen ympäristökeskuksen moniste 328	
Publikationens tema		
Projektets namn och nummer		
Finansiär/ uppdragsgivare		
Organisationer i projektgruppen		
	ISSN 1455-0792	ISBN 952-11-2053-3 952-11-2054-1 (pdf)
	Sidantal 128	Språk English
	Offentlighet publik	Pris -
Beställningar/ distribution	Finlands Miljöcentral, informationstjänsten <a href="mailto:neuvota.syke@ymparisto.fi">neuvota.syke@ymparisto.fi</a> , tfn (09) 4030 0119, fax (09) 4030 0190	
Förläggare	Finlands miljöcentral PB 140, 00251 Helsingfors	
Tryckeri/ tryckningsort och -år	Edita Prima Ab Helsingfors 2005	
Övriga uppgifter		

ISBN 952-11-2053-3

ISBN 952-11-2054-1 (PDF)

ISSN 1455-0792

